



### General Description

The SLG59M1618V is a 19 mΩ 2.0 A single-channel load switch that is able to switch 0.85 to 5 V power rails. The product is packaged in an ultra-small 1.0 x 1.4 mm package.

### Features

- 1.0 x 1.4 mm STDFN, 0.4 mm pin pitch package
- Logic level ON pin capable of supporting 0.85 V CMOS Logic
- User selectable ramp rate with external capacitor
- 19 mΩ RDS<sub>ON</sub> while supporting 2.0 A
- Over Temperature Protection
- Pb-Free / Halogen-Free / RoHS compliant
- Operating Temperature: -40 °C to 85°C
- Operating Voltage: 2.5 V to 5.5 V

### Pin Configuration

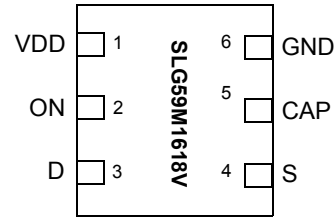

**6-pin STDFN  
(Top View)**

### Applications

- Notebook Power Rail Switching
- Tablet Power Rail Switching
- Smartphone Power Rail Switching

### Block Diagram

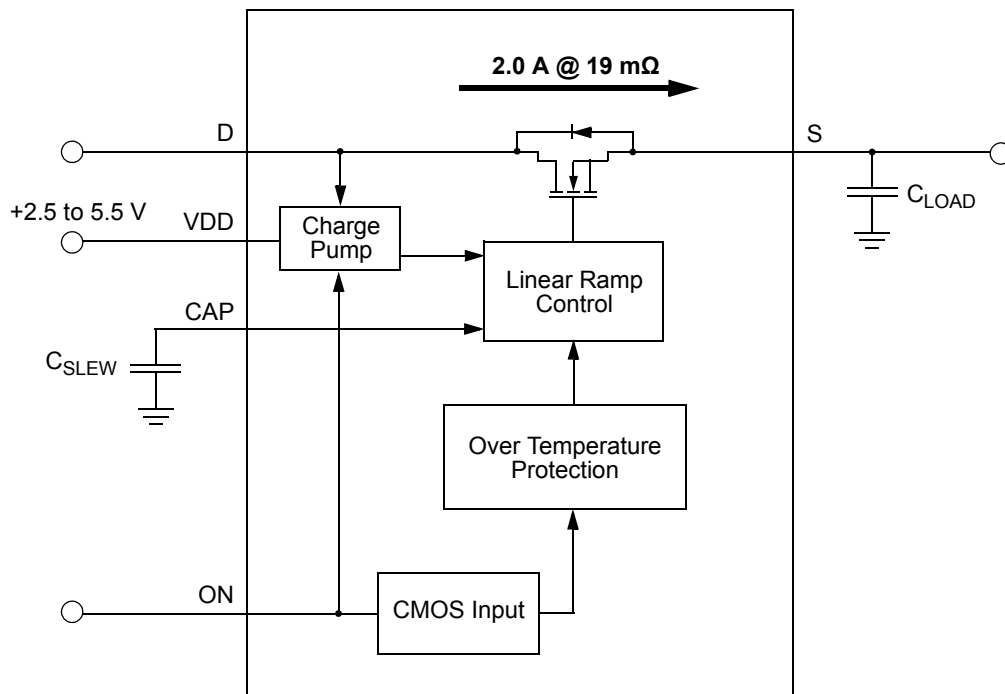



### Pin Description

Pin #	Pin Name	Type	Pin Description
1	VDD	Power	With an internal 1.9 V UVLO threshold, VDD supplies the power for the operation of the power switch and internal control circuitry. Bypass the VDD pin to GND with a 0.1 $\mu$ F (or larger) capacitor.
2	ON	Input	A low-to-high transition on this pin initiates the operation of the SLG59M1618V's state machine. ON is an asserted HIGH, level-sensitive CMOS input with $V_{IL} < 0.3$ V and $V_{IH} > 0.85$ V. While there is an internal pull-down circuit to GND ( $\sim 4$ M $\Omega$ ), connect this pin directly to a general-purpose output (GPO) of a microcontroller, an application processor, or a system controller – do not allow this pin to be open-circuited.
3	D	MOSFET	Drain terminal connection of the n-channel FET. Connect a 10 $\mu$ F (or larger) low-ESR capacitor from this pin to ground. Capacitors used at D should be rated at 10 V or higher.
4	S	MOSFET	Source terminal connection of the n-channel FET. Connect a 10 $\mu$ F (or larger) low-ESR capacitor from this pin to ground. Capacitors used at S should be rated at 10 V or higher.
5	CAP	Output	A low-ESR, stable dielectric, ceramic surface-mount capacitor connected from CAP pin to GND sets the $V_S$ slew rate and overall turn-on time of the SLG59M1618V. For best performance, the range for $C_{SLEW}$ values are $1$ nF $\leq C_{SLEW} \leq 22$ nF. Capacitors used at CAP should be rated at 10 V or higher.
6	GND	GND	Ground connection. Connect this pin to system analog or power ground plane.

### Ordering Information

Part Number	Type	Production Flow
SLG59M1618V	STDFN 6L	Industrial, -40 °C to 85 °C
SLG59M1618VTR	STDFN 6L (Tape and Reel)	Industrial, -40 °C to 85 °C



## Absolute Maximum Ratings

Parameter	Description	Conditions	Min.	Typ.	Max.	Unit
V <sub>DD</sub>	Power Supply		--	--	6	V
T <sub>S</sub>	Storage Temperature		-65	--	150	°C
ESD <sub>HBM</sub>	ESD Protection	Human Body Model	2000	--	--	V
ESD <sub>CDM</sub>	ESD Protection	Charged Device Model	1000	--	--	V
MSL	Moisture Sensitivity Level		1			
θ <sub>JA</sub>	Thermal Resistance	1.0 x 1.4 mm 6L STDFN; Determined using 1 in <sup>2</sup> , 1 oz. copper pads under VD and VS terminals and FR4 pcb material	--	72	--	°C/W
W <sub>DIS</sub>	Package Power Dissipation		--	--	0.4	W
MOSFET IDS <sub>PK</sub>	Peak Current from Drain to Source	Maximum pulsed switch current, pulse width < 1ms, 1% duty cycle	--	--	3	A

Note: Stresses greater than those listed under "Absolute Maximum Ratings" may cause permanent damage to the device. This is a stress rating only and functional operation of the device at these or any other conditions above those indicated in the operational sections of this specification is not implied. Exposure to absolute maximum rating conditions for extended periods may affect reliability.

## Electrical Characteristics

T<sub>A</sub> = -40 °C to 85 °C (unless otherwise stated)

Parameter	Description	Conditions	Min.	Typ.	Max.	Unit
V <sub>DD</sub>	Power Supply Voltage	-40 °C to 85 °C	2.5	--	5.5	V
V <sub>DD(UVLO)</sub>	V <sub>DD</sub> Undervoltage Lockout Threshold		1.6	1.9	2.2	V
I <sub>DD</sub>	Power Supply Current (PIN 1)	when OFF	--	--	1	μA
		when ON, No load	--	100	120	μA
RDS <sub>ON</sub>	Static Drain to Source ON Resistance	T <sub>A</sub> 25°C @ 100 mA	--	19	22	mΩ
		T <sub>A</sub> 85°C @ 100 mA	--	20	25	mΩ
MOSFET IDS	Current from Drain to Source	Continuous	--	--	2.0	A
V <sub>D</sub>	Drain Voltage		0.85	--	V <sub>DD</sub>	V
T <sub>ON_Delay</sub>	ON pin Delay Time	50% ON to Ramp Begin	--	400	600	μs
T <sub>Total_ON</sub>	Total Turn On Time	50% ON to 90% V <sub>S</sub>	Configurable <sup>1</sup>			ms
		Example: C <sub>SLEW</sub> = 4 nF; V <sub>DD</sub> = V <sub>D</sub> = 5 V, C <sub>LOAD</sub> = 10 μF, R <sub>LOAD</sub> = 20 Ω	--	1.80	--	ms
V <sub>S(SR)</sub>	V <sub>S</sub> Slew Rate	10% V <sub>S</sub> to 90% V <sub>S</sub>	Configurable <sup>1</sup>			V/ms
		Example: C <sub>SLEW</sub> = 4 nF; V <sub>DD</sub> = V <sub>D</sub> = 5 V, C <sub>LOAD</sub> = 10 μF, R <sub>LOAD</sub> = 20 Ω	--	3	--	V/ms
C <sub>LOAD</sub>	Output Load Capacitance	C <sub>LOAD</sub> connected from S to GND	--	--	500	μF
ON_V <sub>IH</sub>	High Input Voltage on ON pin		0.85	--	V <sub>DD</sub>	V
ON_V <sub>IL</sub>	Low Input Voltage on ON pin		-0.3	0	0.3	V
THERM <sub>ON</sub>	Thermal shutoff turn-on temperature		--	130	--	°C
THERM <sub>OFF</sub>	Thermal shutoff turn-off temperature		--	100	--	°C
THERM <sub>TIME</sub>	Thermal shutoff time		--	--	1	ms
T <sub>OFF_Delay</sub>	OFF Delay Time	50% ON to V <sub>S</sub> Fall, V <sub>DD</sub> = V <sub>D</sub> = 5 V, R <sub>LOAD</sub> = 20 Ω, no C <sub>LOAD</sub>	--	2.0	--	μs



### Electrical Characteristics (continued)

T<sub>A</sub> = -40 °C to 85 °C (unless otherwise stated)

Parameter	Description	Conditions	Min.	Typ.	Max.	Unit
T <sub>FALL</sub>	V <sub>S</sub> Fall Time	90% V <sub>S</sub> to 10% V <sub>S</sub> , V <sub>DD</sub> = V <sub>D</sub> = 5 V, R <sub>LOAD</sub> = 20 Ω, no C <sub>LOAD</sub>	--	0.25	--	μs

Notes:

1. Refer to table for configuration details.



## $T_{Total\_ON}$ , $T_{ON\_Delay}$ and Slew Rate Measurement

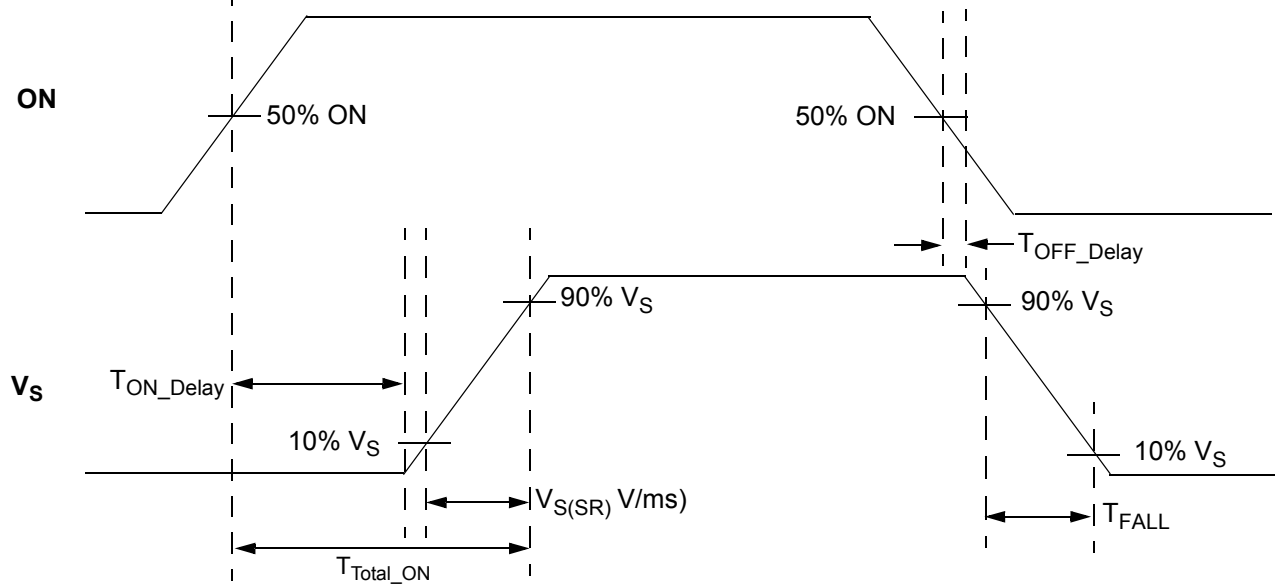

\* Rise and Fall times of the ON signal are 100 ns

## Typical Performance Characteristics

### $R_{DS(ON)}$ vs. $V_{DD}$ and Temperature

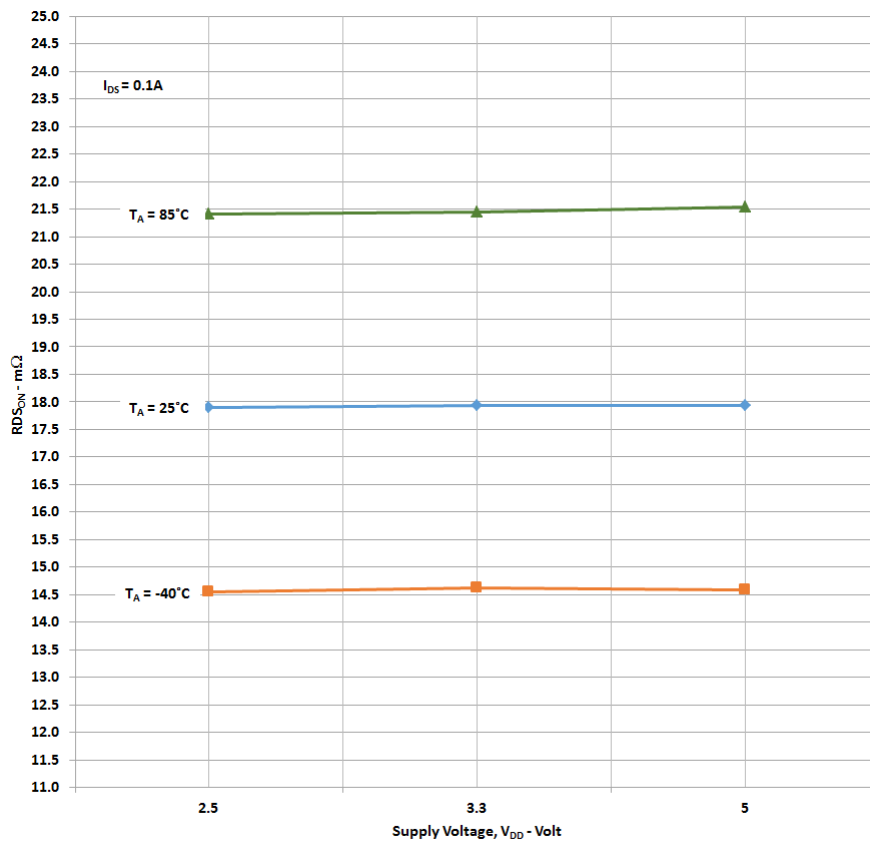



RDS<sub>ON</sub> vs. V<sub>D</sub> and V<sub>DD</sub>

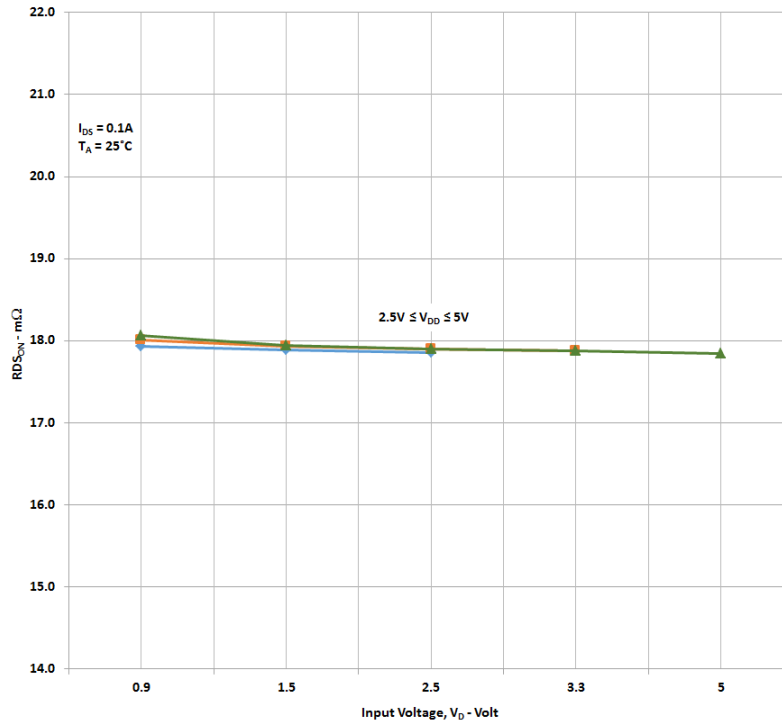

V<sub>S</sub> Slew Rate vs. Temperature, V<sub>DD</sub>, V<sub>D</sub>, and C<sub>SLEW</sub>

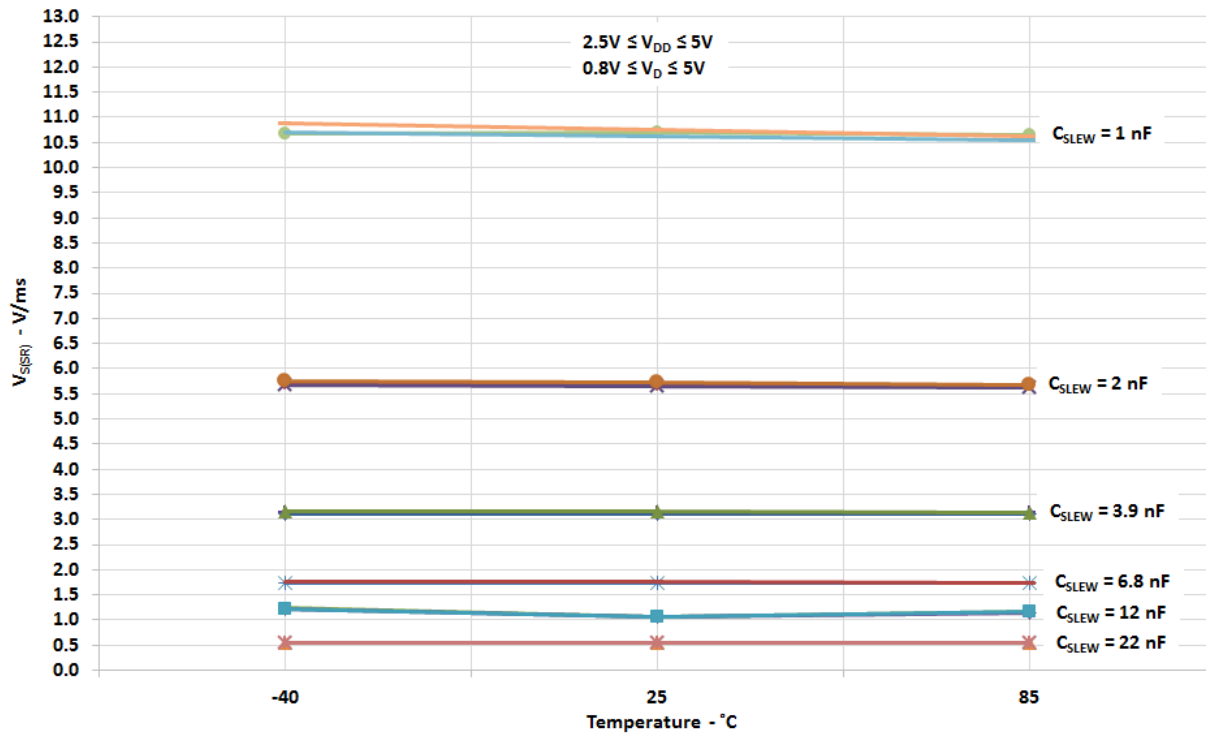



### $T_{Total\_ON}$ vs. $C_{SLEW}$ , $V_D$ , $V_{DD}$ , and Temperature

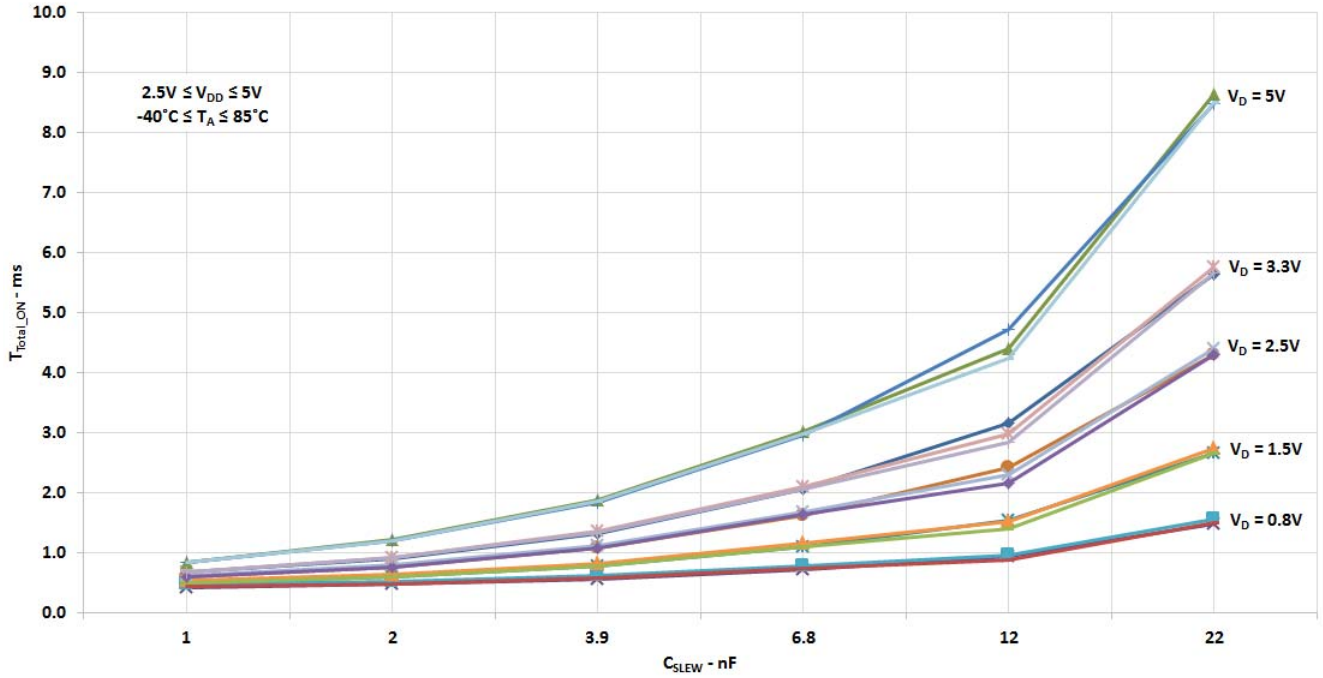



## Typical Turn-on Waveforms

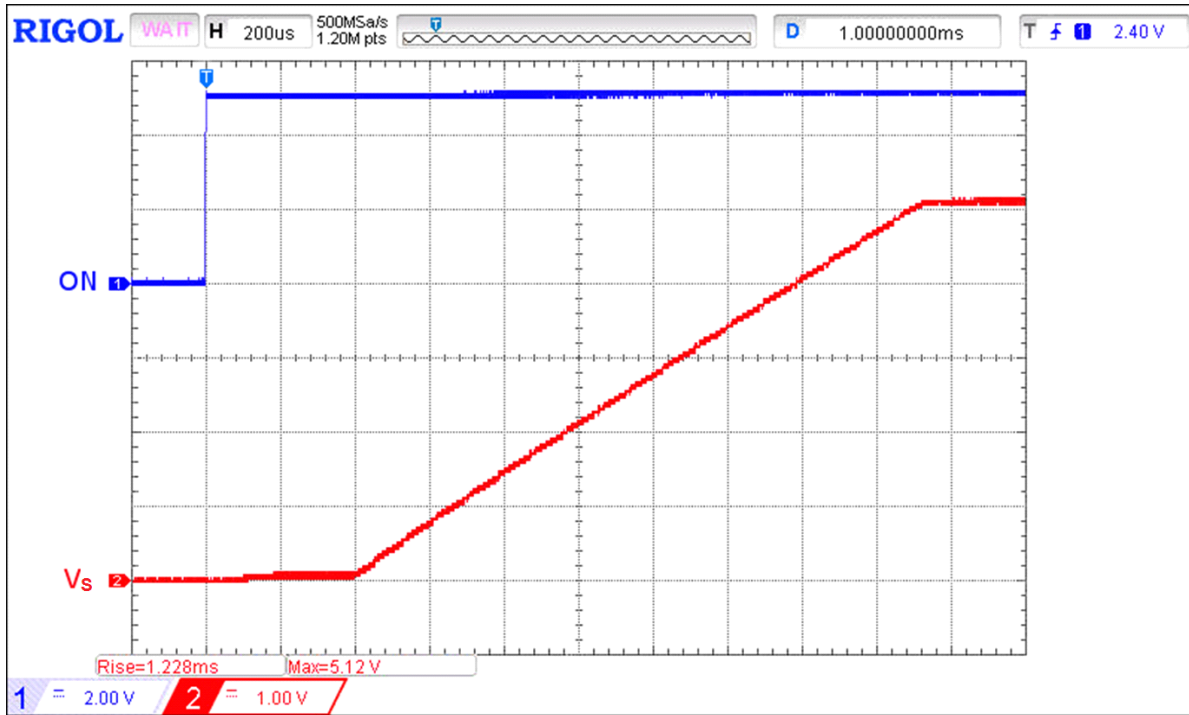

Figure 1. Typical Turn ON operation waveform for  $V_D = 5\text{ V}$ ,  $C_{SLEW} = 4\text{ nF}$ ,  $C_{LOAD} = 10\text{ }\mu\text{F}$ ,  $R_{LOAD} = 20\text{ }\Omega$



Figure 2. Typical Turn ON operation waveform for  $V_D = 5\text{ V}$ ,  $C_{SLEW} = 12\text{ nF}$ ,  $C_{LOAD} = 10\text{ }\mu\text{F}$ ,  $R_{LOAD} = 20\text{ }\Omega$





### Typical Turn-off Waveforms

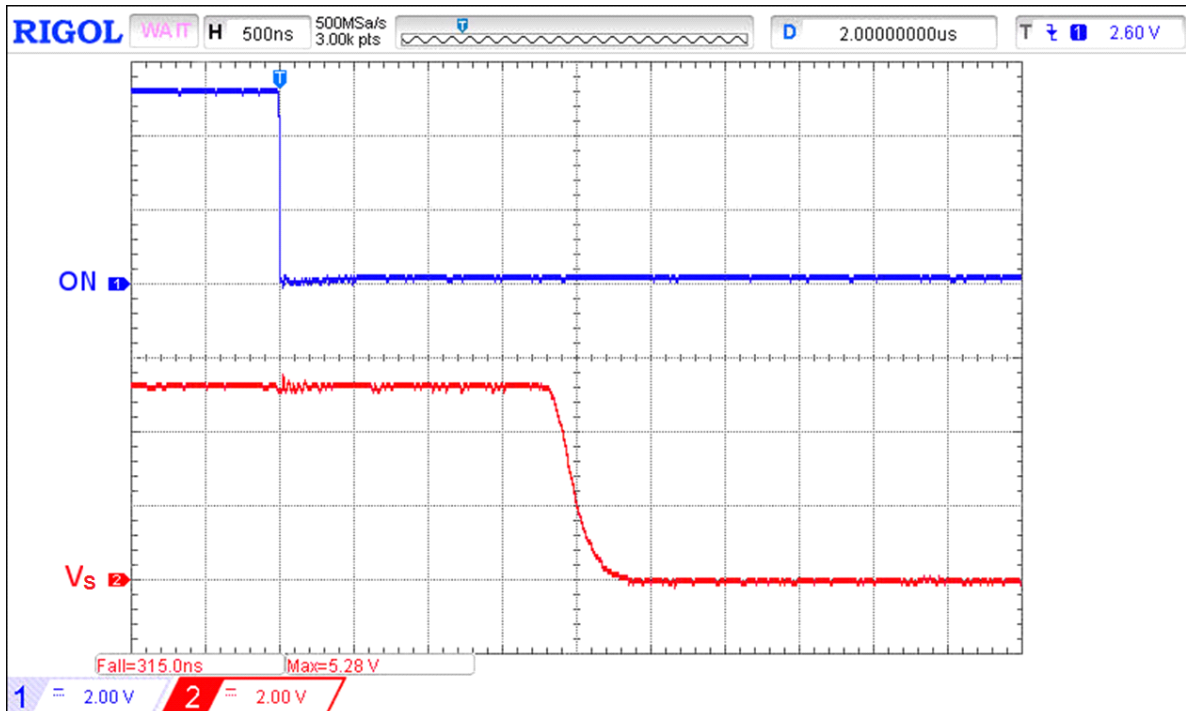

Figure 3. Typical Turn OFF operation waveform for  $V_D = 5\text{ V}$ ,  $C_{SLEW} = 4\text{ nF}$ , no  $C_{LOAD}$ ,  $R_{LOAD} = 20\ \Omega$

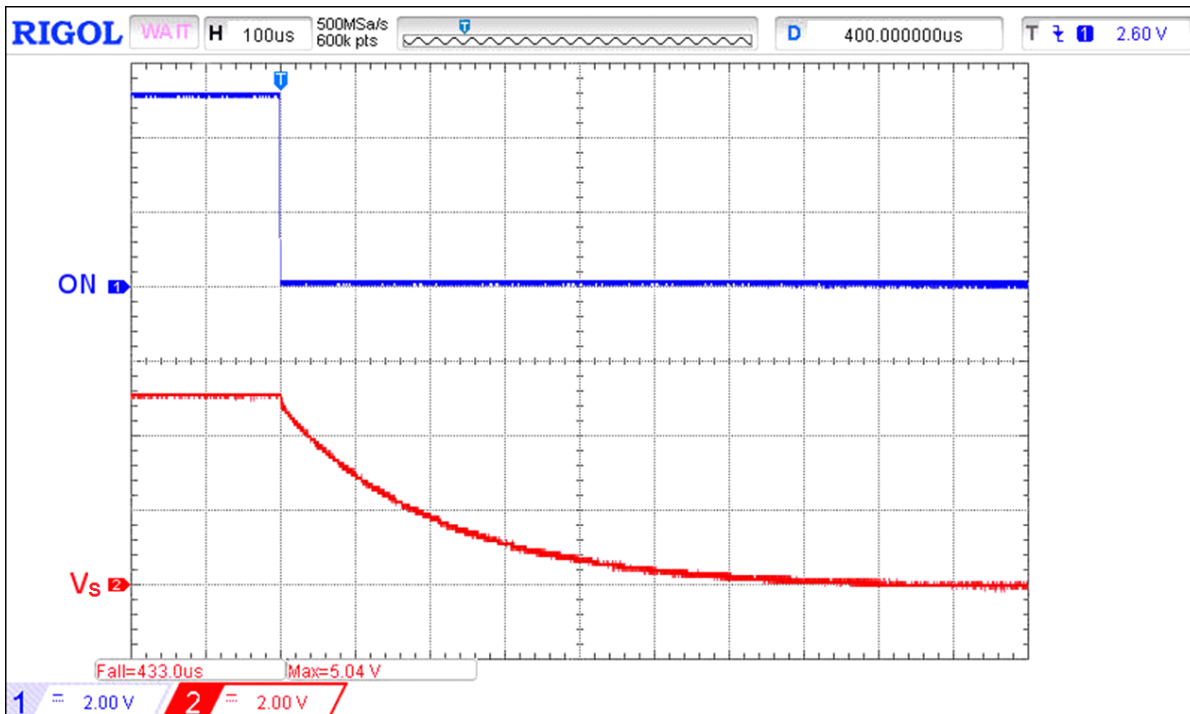

Figure 4. Typical Turn OFF operation waveform for  $V_D = 5\text{ V}$ ,  $C_{SLEW} = 4\text{ nF}$ ,  $C_{LOAD} = 10\ \mu\text{F}$ ,  $R_{LOAD} = 20\ \Omega$



### SLG59M1618V Power-Up/Power-Down Sequence Considerations

To ensure glitch-free power-up under all conditions, apply  $V_{DD}$  first, followed by  $V_D$  after  $V_{DD}$  exceeds 1.9 V. Then allow  $V_D$  to reach 90% of its max value before toggling the ON pin from Low-to-High. Likewise, power-down in reverse order.

If  $V_{DD}$  and  $V_D$  need to be powered up simultaneously, glitching can be minimized by having a suitable load capacitor. A 10  $\mu\text{F}$   $C_{LOAD}$  will prevent glitches for rise times of  $V_{DD}$  and  $V_D$  less than 2 ms.

If the ON pin is toggled HIGH before  $V_{DD}$  and  $V_D$  have reached their steady-state values, the IPS timing parameters may differ from datasheet specifications.

The slew rate of output  $V_S$  follows a linear ramp set by a capacitor connected to the CAP pin. A larger capacitor value at the CAP pin produces a slower ramp, reducing inrush current from capacitive loads.

### SLG59M1618V Thermal Shutdown Operation

If a load-current overload condition persists where the die temperature rises because of the increased FET resistance, the power switch's internal Thermal Shutdown Protection circuit can be activated. If the die temperature exceeds the listed  $THERM_{ON}$  specification, the FET is shut OFF completely, thereby allowing the die to cool. When the die cools to the listed  $THERM_{OFF}$  temperature threshold, the FET is allowed to turn back on. This process may repeat as long as the output current overload condition persists.

For more information on Silego GreenFET3 integrated power switch features, please visit our [Application Notes](#) page at our website and see [App Note "AN-1068 GreenFET3 Integrated Power Switch Basics"](#).



---

Package Top Marking System Definition

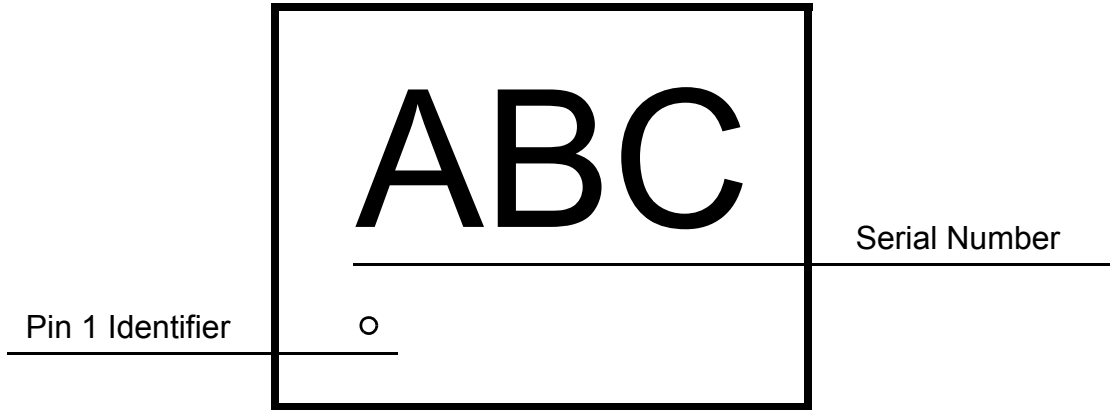

ABC - Part Serial Number Field  
each A, B, and C character can be A-Z and 0-9



### Package Drawing and Dimensions

6 Lead STDFN Package 1.0 x 1.4 mm

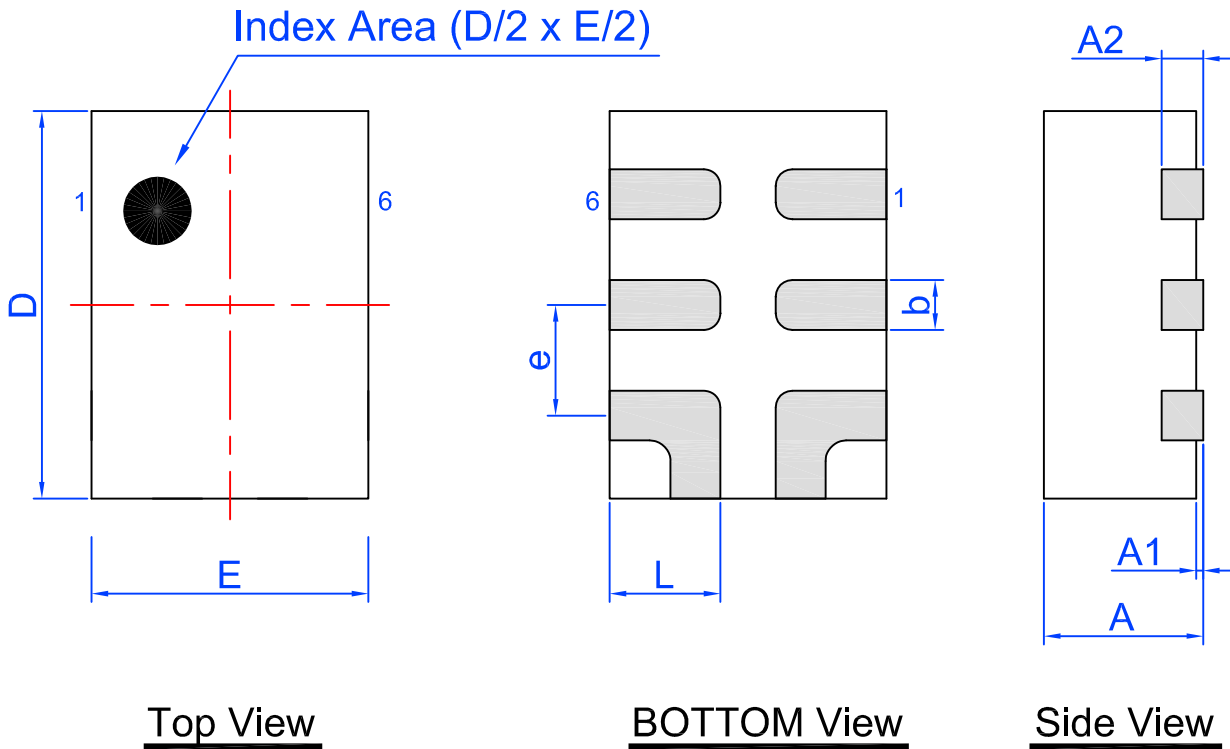

Unit: mm

Symbol	Min	Nom.	Max	Symbol	Min	Nom.	Max
A	0.50	0.55	0.60	D	1.35	1.40	1.45
A1	0.005	-	0.060	E	0.95	1.00	1.05
A2	0.10	0.15	0.20	L	0.35	0.40	0.45
b	0.13	0.18	0.23	e	0.40 BSC		



**Tape and Reel Specifications**

Package Type	# of Pins	Nominal Package Size [mm]	Max Units		Reel & Hub Size [mm]	Leader (min)		Trailer (min)		Tape Width [mm]	Part Pitch [mm]
			per Reel	per Box		Pockets	Length [mm]	Pockets	Length [mm]		
STDFN 6L 1x1.4mm 0.4P FC Green	6	1.0 x 1.4 x 0.55	3,000	3,000	178 / 60	100	400	100	400	8	4

**Carrier Tape Drawing and Dimensions**

Package Type	Pocket BTM Length	Pocket BTM Width	Pocket Depth	Index Hole Pitch	Pocket Pitch	Index Hole Diameter	Index Hole to Tape Edge	Index Hole to Pocket Center	Tape Width
	A0	B0	K0	P0	P1	D0	E	F	W
STDFN 6L 1x1.4mm 0.4P FC Green	1.21	1.62	0.75	4	4	1.5	1.75	3.5	8

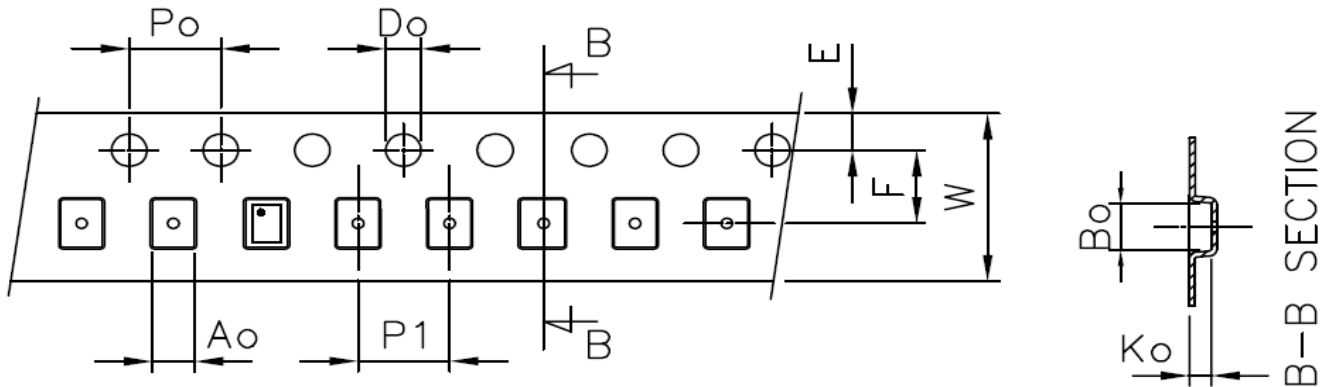

**Recommended Reflow Soldering Profile**

Please see IPC/JEDEC J-STD-020: latest revision for reflow profile based on package volume of 0.77 mm<sup>3</sup> (nominal). More information can be found at [www.jedec.org](http://www.jedec.org).



**Revision History**

Date	Version	Change
2/23/2017	1.00	Production Release