

SLG59M1545V

An Ultra-small, 17 mΩ, 2.5 A Load Switch

General Description

The SLG59M1545V is a 17 mΩ 2.5 A single-channel load switch that is able to switch 0.85 V to 5.5 V power rails. The product is packaged in an ultra-small 1.0 x 1.6 mm package.

Features

- 1.0 x 1.6 x 0.55 mm STDFN package (2 fused pins for drain and 2 fused pins for source)
- Logic level ON pin capable of supporting 0.85 V CMOS Logic
- User selectable ramp rate with external capacitor
- 17 mΩ RDS_{ON} while supporting 2.5 A
- Two Over Current Protection Modes
 - Short Circuit Current Limit
 - Active Current Limit
- Over Temperature Protection
- Pb-Free / Halogen-Free / RoHS compliant
- Operating Temperature: -20 °C to 70 °C
- Operating Voltage: 2.5 V to 5.5 V

Pin Configuration

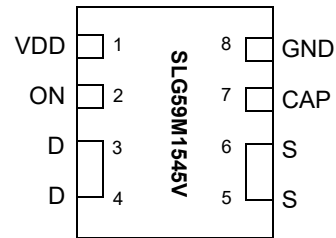

8-pin STDFN
(Top View)

Applications

- Notebook Power Rail Switching
- Tablet Power Rail Switching
- Smartphone Power Rail Switching

Block Diagram

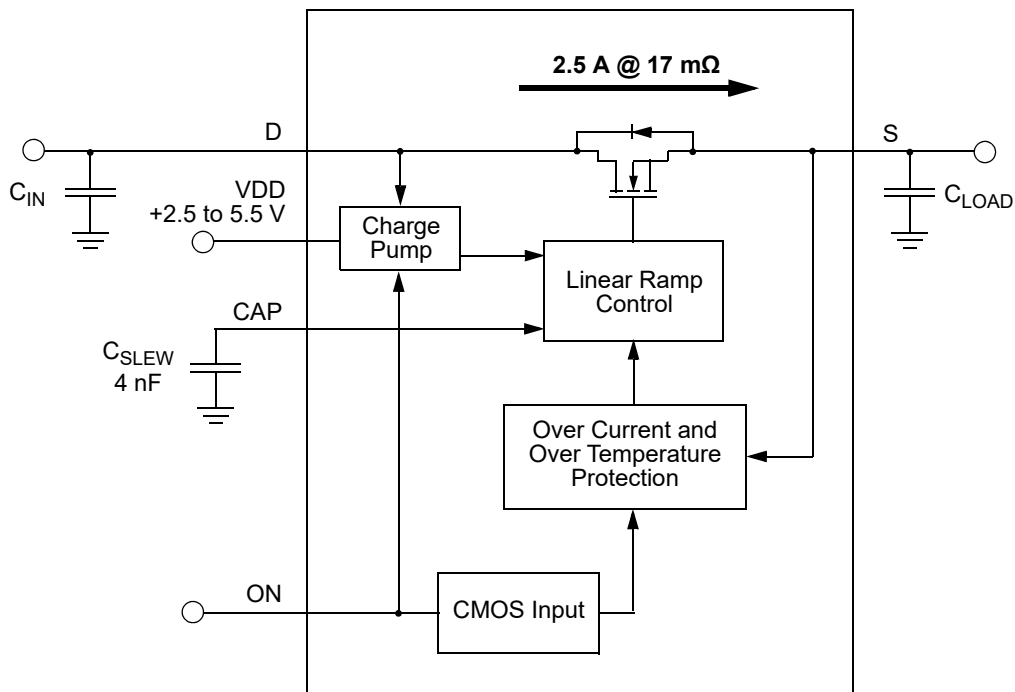

Pin Description

Pin #	Pin Name	Type	Pin Description
1	VDD	PWR	VDD supplies the power for the operation of the power switch and internal control circuitry. Bypass the VDD pin to GND with a 0.1 μF (or larger) capacitor.
2	ON	Input	A low-to-high transition on this pin initiates the operation of the SLG59M1545V's state machine. ON is a CMOS input with ON_V _{IL} < 0.3 V and ON_V _{IH} > 0.85 V thresholds. While there is an internal pull-down circuit to GND (~4 MΩ), connect this pin directly to a general-purpose output (GPO) of a microcontroller, an application processor, or a system controller.
3, 4	D	MOSFET	Drain terminal connection of the n-channel MOSFET (2 pins fused for D). Connect at least a low-ESR 0.1 μF capacitor from this pin to ground. Capacitors used at D should be rated at 10 V or higher.
5, 6	S	MOSFET	Source terminal connection of the n-channel MOSFET (2 pins fused for S). Connect a low-ESR capacitor from this pin to ground and consult the Electrical Characteristics table for recommended C _{LOAD} range. Capacitors used at S should be rated at 10 V or higher.
7	CAP	Input	A low-ESR, stable dielectric, ceramic surface-mount capacitor connected from CAP pin to GND sets the V _S slew rate and overall turn-on time of the SLG59M1545V. For best performance C _{SLEW} value should be ≥ 1.5 nF and voltage level should be rated at 10 V or higher.
8	GND	GND	Ground connection. Connect this pin to system analog or power ground plane.

Ordering Information

Part Number	Type	Production Flow
SLG59M1545V	STDFN 8L	Commercial, -20 °C to 70 °C
SLG59M1545VTR	STDFN 8L (Tape and Reel)	Commercial, -20 °C to 70 °C

Absolute Maximum Ratings

Parameter	Description	Conditions	Min.	Typ.	Max.	Unit
V_{DD}	Power Supply		-0.3	--	7	V
V_D to GND	Power Switch Input Voltage to GND		-0.3	--	V_{DD}	V
V_S to GND	Power Switch Output Voltage to GND		-0.3	--	V_D	V
ON and CAP to GND	ON and CAP Pin Voltages to GND		-0.3	--	V_{DD}	V
T_S	Storage Temperature		-65	--	150	°C
ESD _{HBM}	ESD Protection	Human Body Model	2000	--	--	V
ESD _{CDM}	ESD Protection	Charged Device Model	500	--	--	V
θ_{JA}	Thermal Resistance	1 x 1.6 mm, 8L STDFN; Determined using 1 in ² , 1 oz. copper pads under each D and S terminals and FR4 pcb material	--	72	--	°C/W
MOSFET $I_{DS_{PK}}$	Peak Current from Drain to Source	For no more than 1 ms with 1% duty cycle	--	--	3.5	A

Note: Stresses greater than those listed under "Absolute Maximum Ratings" may cause permanent damage to the device. This is a stress rating only and functional operation of the device at these or any other conditions above those indicated in the operational sections of this specification is not implied. Exposure to absolute maximum rating conditions for extended periods may affect reliability.

Electrical Characteristics

$T_A = -20\text{ °C}$ to 70 °C unless otherwise noted.

Parameter	Description	Conditions	Min.	Typ.	Max.	Unit
V_{DD}	Power Supply Voltage	-20 °C to 70 °C	2.5	--	5.5	V
I_{DD}	Power Supply Current (PIN 1)	when OFF	--	--	1	μA
		when ON, No load	--	75	100	μA
RDS _{ON}	ON Resistance	$T_A = 25\text{ °C}$, $I_{DS} = 100\text{ mA}$	--	17	19	mΩ
		$T_A = 70\text{ °C}$, $I_{DS} = 100\text{ mA}$	--	18.5	20	mΩ
MOSFET I_{DS}	Current from D to S	Continuous	--	--	2.5	A
V_D	Drain Voltage		0.85	--	V_{DD}	V
T_{ON_Delay}	ON Delay Time	50% ON to V_S Ramp Start; $C_{LOAD} = 10\text{ μF}$, $R_{LOAD} = 20\text{ Ω}$	--	300	500	μs
T_{Total_ON}	Total Turn On Time	50% ON to 90% V_S	Set by External C_{SLEW}^1			ms
		Example: $C_{SLEW} = 4\text{ nF}$, $V_{DD} = V_D = 5\text{ V}$, $C_{LOAD} = 10\text{ μF}$, $R_{LOAD} = 20\text{ Ω}$	--	1.50	--	ms
$V_{S(SR)}$	Slew Rate	10% V_S to 90% V_S	Set by External C_{SLEW}^1			V/ms
		Example: $C_{SLEW} = 4\text{ nF}$, $V_{DD} = V_D = 5\text{ V}$, $C_{LOAD} = 10\text{ μF}$, $R_{LOAD} = 20\text{ Ω}$	--	3.4	--	V/ms
C_{LOAD}	Output Load Capacitance	C_{LOAD} connected from S to GND	--	--	500	μF
ON_ V_{IH}	High Input Voltage on ON pin		0.85	--	V_{DD}	V
ON_ V_{IL}	Low Input Voltage on ON pin		-0.3	0	0.3	V

Electrical Characteristics (continued)

T_A = -20 °C to 70 °C unless otherwise noted.

Parameter	Description	Conditions	Min.	Typ.	Max.	Unit
I _{LIMIT}	Active Current Limit, I _{ACL}	MOSFET will automatically limit current when V _S > 250 mV	--	3.7	--	A
	Short Circuit Current Limit, I _{SCL}	MOSFET will automatically limit current when V _S < 250 mV	--	0.9	--	A
THERM _{ON}	Thermal shutoff turn-on temperature		--	125	--	°C
THERM _{OFF}	Thermal shutoff turn-off temperature		--	100	--	°C
THERM _{TIME}	Thermal shutoff time		--	--	1	ms
T _{OFF_Delay}	OFF Delay Time	50% ON to V _S Fall Start; V _{DD} = V _D = 5 V; R _{LOAD} = 20 Ω, no C _{LOAD}	--	8	--	μs
T _{FALL}	V _S Fall Time	90% V _S to 10% V _S , V _{DD} = V _D = 5 V R _{LOAD} = 20 Ω, no C _{LOAD}	--	3.8	--	μs

Notes:
 1. Refer to typical timing parameter vs. C_{SLEW} performance charts for additional information when available.

T_{ON_Delay}, V_{S(SR)}, and T_{Total_ON} Timing Details

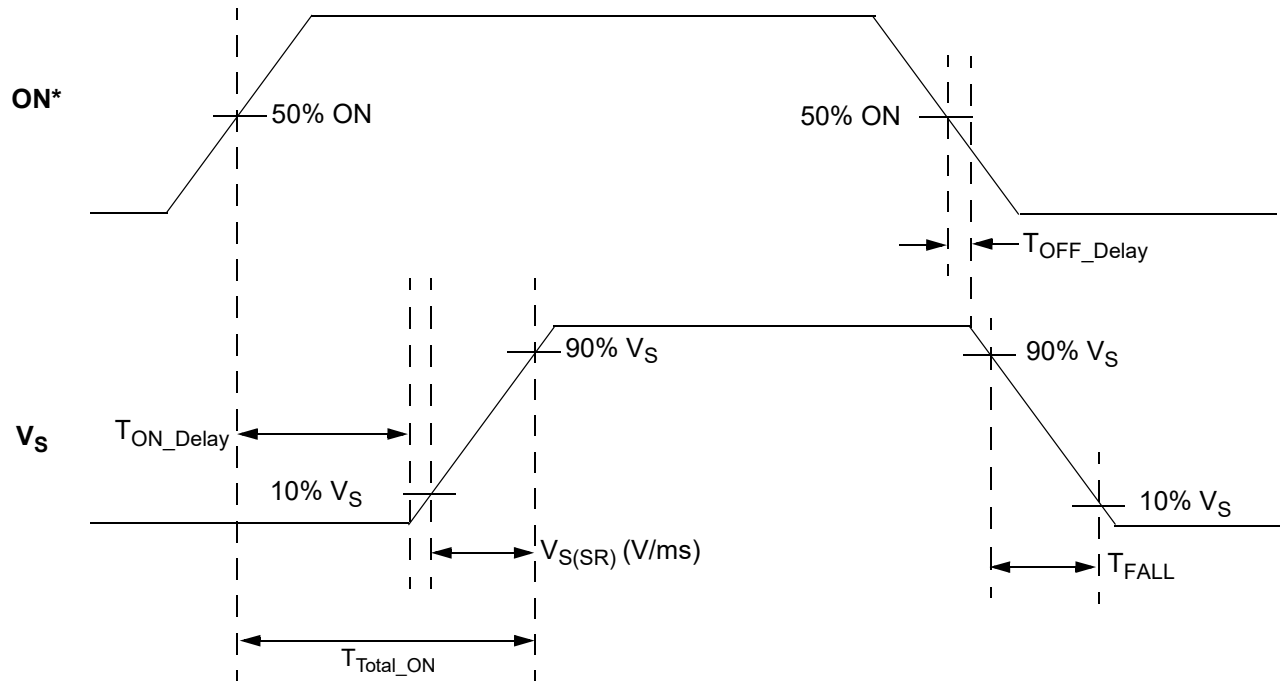

Note: * Rise and Fall times of the ON signal are 100 ns

Typical Performance Characteristics

T_{Total_ON} vs C_{SLEW} , V_D , V_{DD} , and Temperature

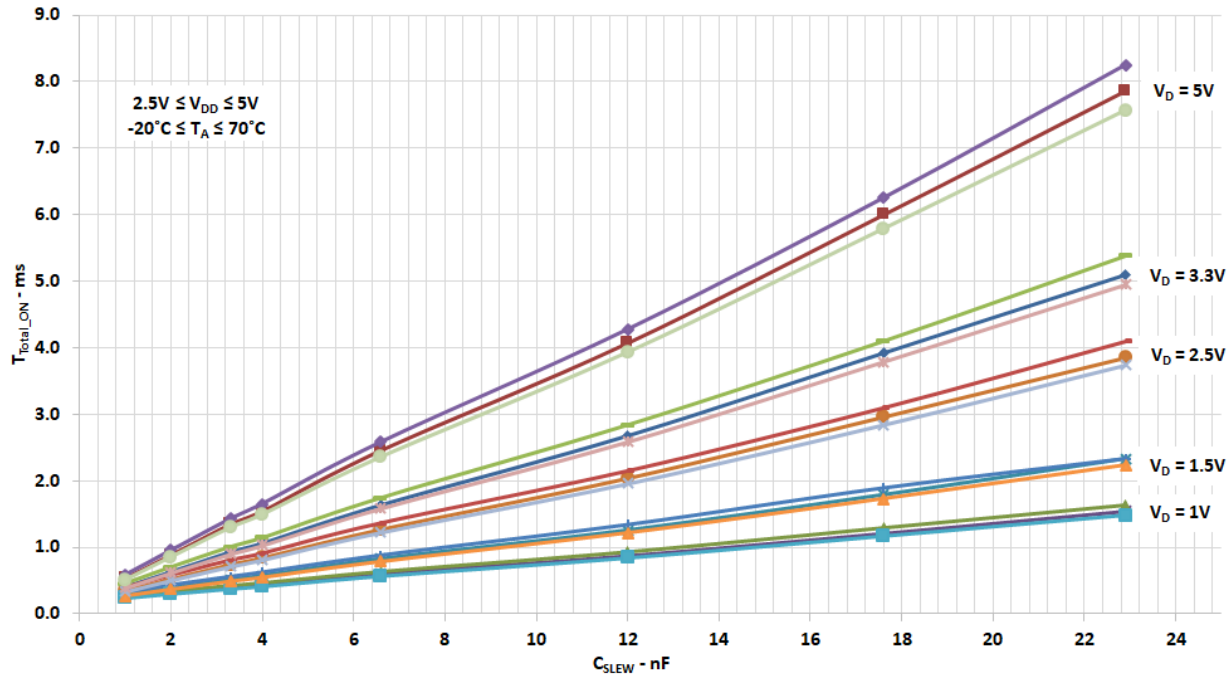

V_S Slew Rate vs. C_{SLEW} , V_{DD} , and Temperature

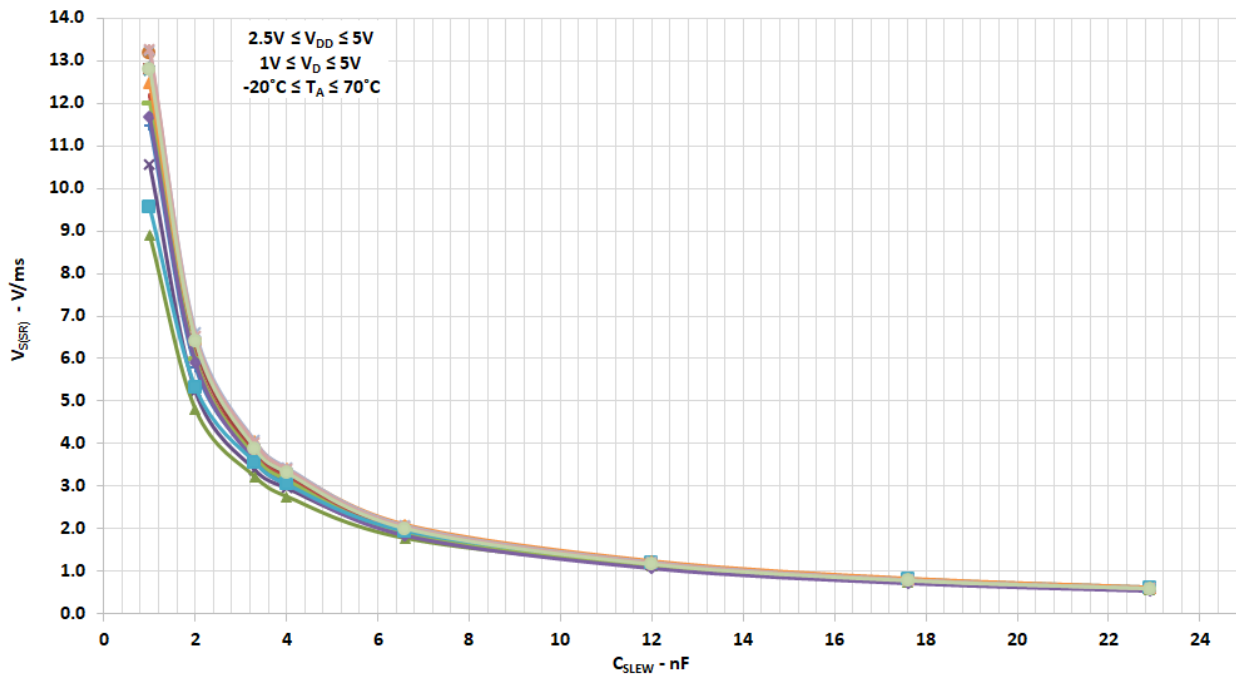

SLG59M1545V Power-Up/Power-Down Sequence Considerations

To ensure glitch-free power-up under all conditions, apply V_{DD} first, followed by V_D after V_{DD} exceeds 1.9 V. Then allow V_D to reach 90% of its max value before toggling the ON pin from Low-to-High. Likewise, power-down in reverse order.

If V_{DD} and V_D need to be powered up simultaneously, glitching can be minimized by having a suitable load capacitor. A 10 μF C_{LOAD} will prevent glitches for rise times of V_{DD} and V_D less than 2 ms.

If the ON pin is toggled HIGH before V_{DD} and V_D have reached their steady-state values, the IPS timing parameters may differ from datasheet specifications.

The slew rate of output V_S follows a linear ramp set by a capacitor connected to the CAP pin. A larger capacitor value at the CAP pin produces a slower ramp, reducing inrush current from capacitive loads.

SLG59M1545V Current Limiting Operation

The SLG59M1545V has two types of current limiting triggered by the output S pin voltage.

1. Standard Current Limiting Mode (with Thermal Shutdown Protection)

When the V_S voltage > 250 mV, the output current is initially limited to the Active Current Limit (I_{ACL}) specification listed in the Electrical Characteristics table. The ACL monitor's response time is very fast and is triggered within a few microseconds to sudden (transient) changes in load current. When a load current overload is detected, the ACL monitor increases the FET resistance to keep the current from exceeding the power switch's I_{ACL} threshold.

However, if a load-current overload condition persists where the die temperature rises because of the increased FET resistance, the power switch's internal Thermal Shutdown Protection circuit can be activated. If the die temperature exceeds the listed $THERM_{ON}$ specification, the FET is shut OFF completely, thereby allowing the die to cool. When the die cools to the listed $THERM_{OFF}$ temperature threshold, the FET is allowed to turn back on. This process may repeat as long as the output current overload condition persists.

2. Short Circuit Current Limiting Mode (with Thermal Shutdown Protection)

When the V_S voltage < 250 mV (which is the case with a hard short, such as a solder bridge on the power rail), the power switch's internal Short-circuit Current Limit (SCL) monitor limits the FET current to approximately 900 mA (the I_{SCL} threshold). While the internal Thermal Shutdown Protection circuit remains enabled and since the I_{SCL} threshold is much lower than the I_{ACL} threshold, thermal shutdown protection may become activated only at higher ambient temperatures.

Power Dissipation

The junction temperature of the SLG59M1545V depends on different factors such as board layout, ambient temperature, and other environmental factors. The primary contributor to the increase in the junction temperature of the SLG59M1545V is the power dissipation of its power MOSFET. Its power dissipation and the junction temperature in nominal operating mode can be calculated using the following equations:

$$PD = RDS_{ON} \times I_{DS}^2$$

where:

PD = Power dissipation, in Watts (W)

RDS_{ON} = Power MOSFET ON resistance, in Ohms (Ω)

I_{DS} = Output current, in Amps (A)

and

$$T_J = PD \times \theta_{JA} + T_A$$

where:

T_J = Junction temperature, in Celsius degrees (°C)

θ_{JA} = Package thermal resistance, in Celsius degrees per Watt (°C/W)

T_A = Ambient temperature, in Celsius degrees (°C)

During active current-limit operation, the SLG59M1545V's power dissipation can be calculated by taking into account the voltage drop across the power switch (V_D - V_S) and the magnitude of the output current in active current-limit operation (I_{ACL}):

$$PD = (V_D - V_S) \times I_{ACL} \text{ or}$$

$$PD = (V_D - (R_{LOAD} \times I_{ACL})) \times I_{ACL}$$

where:

PD = Power dissipation, in Watts (W)

V_D = Input Voltage, in Volts (V)

R_{LOAD} = Load Resistance, in Ohms (Ω)

I_{ACL} = Output limited current, in Amps (A)

V_S = R_{LOAD} × I_{ACL}

For more information on Dialog GreenFET3 integrated power switch features, please visit our [Documents](#) search page at our website and see [App Note "AN-1068 GreenFET3 Integrated Power Switch Basics"](#).

Layout Guidelines:

1. The VDD pin needs a 0.1 μF and 10 μF external capacitors to smooth pulses from the power supply. Locate these capacitors as close as possible to the SLG59M1545V's PIN1.
2. Since the D and S pins dissipate most of the heat generated during high-load current operation, it is highly recommended to make power traces as short, direct, and wide as possible. A good practice is to make power traces with absolute minimum widths of 15 mils (0.381 mm) per Ampere. A representative layout, shown in [Figure 1](#), illustrates proper techniques for heat to transfer as efficiently as possible out of the device;
3. To minimize the effects of parasitic trace inductance on normal operation, it is recommended to connect input C_{IN} and output C_{LOAD} low-ESR capacitors as close as possible to the SLG59M1545V's D and S pins;
4. The GND pin should be connected to system analog or power ground plane.
5. 2 oz. copper is recommended for high current operation.

SLG59M1545V Evaluation Board:

A GFET3 Evaluation Board for SLG59M1545V is designed according to the statements above and is illustrated on Figure 1. Please note that evaluation board has D_Sense and S_Sense pads. They cannot carry high currents and dedicated only for RDS_{ON} evaluation.

Please solder your SLG59M1545V here

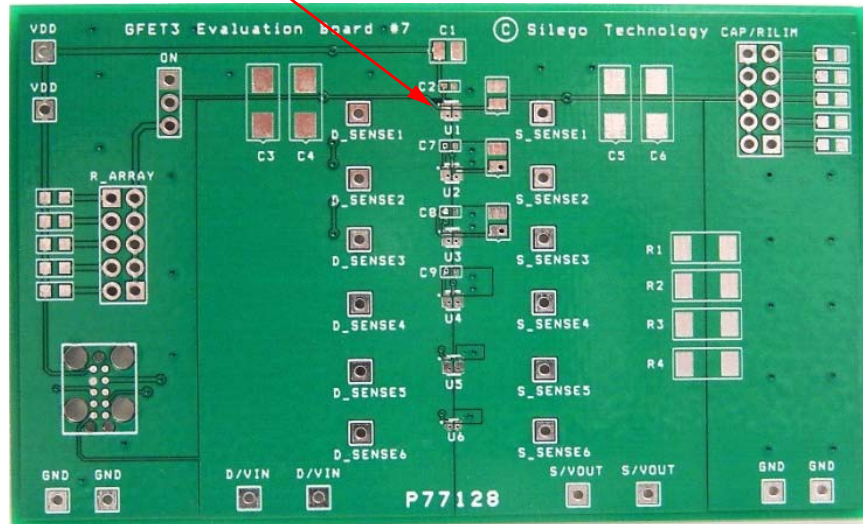

Figure 1. SLG59M1545V Evaluation Board.

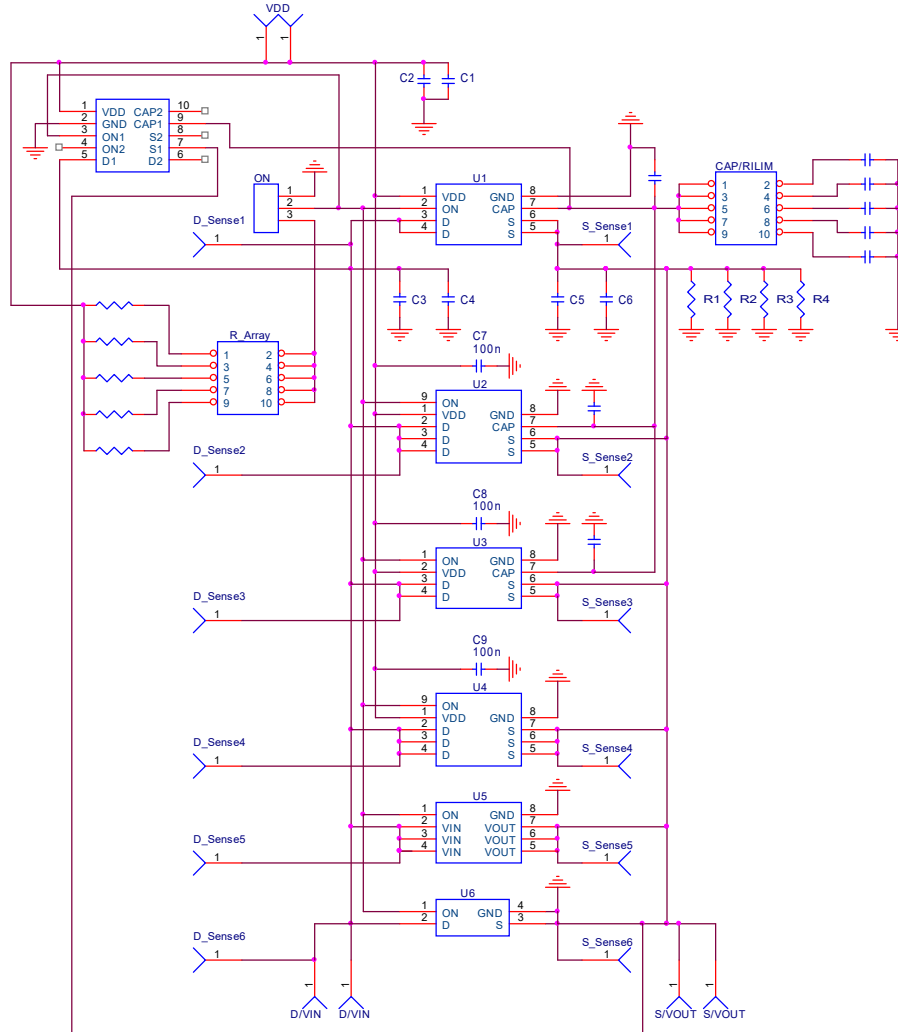

Figure 2. SLG59M1545V Evaluation Board Connection Circuit.

Basic Test Setup and Connections

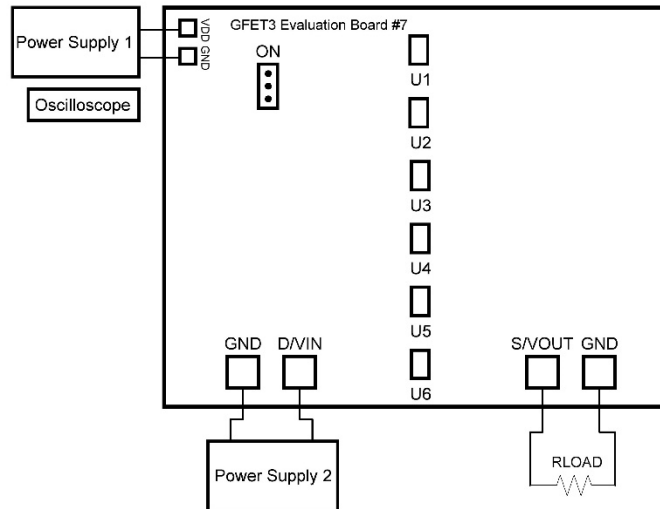
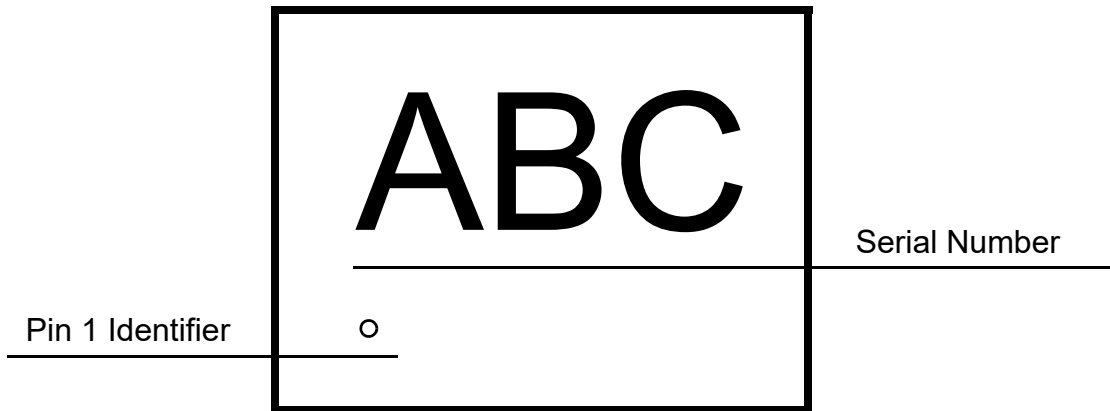

Figure 3. Typical connections for GFET3 Evaluation.

EVB Configuration

1. Connect oscilloscope probes to D/VIN, S/VOUT, ON, etc.;
2. Turn on Power Supply 1 and set desired V_{DD} from 2.5 V...5.5 V range;
3. Turn on Power Supply 2 and set desired V_D from 0.85 V...5.5 V range;
4. Toggle the ON signal High or Low to observe SLG59M1545V operation.

Package Top Marking System Definition



ABC - 3 alphanumeric Part Serial Number
where A, B, or C can be A-Z and 0-9

Package Drawing and Dimensions

8 Lead STDFN Package 1.0 x 1.6 mm (Fused Lead)

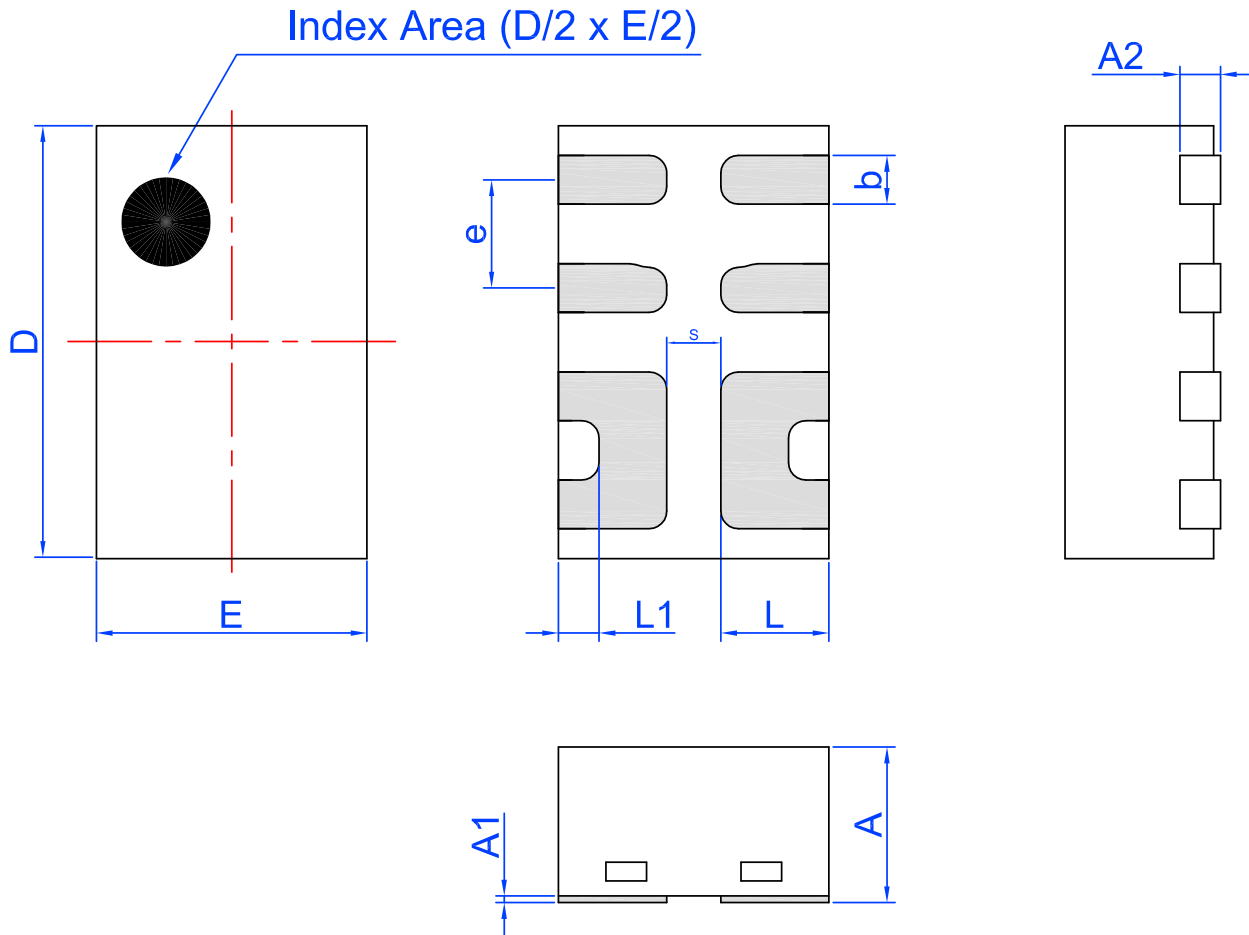

Unit: mm

Symbol	Min	Nom.	Max	Symbol	Min	Nom.	Max
A	0.50	0.55	0.60	D	1.55	1.60	1.65
A1	0.005	-	0.060	E	0.95	1.00	1.05
A2	0.10	0.15	0.20	L	0.35	0.40	0.45
b	0.13	0.18	0.23	L1	0.10	0.15	0.20
e	0.40 BSC			S	0.2 REF		

Tape and Reel Specifications

Package Type	# of Pins	Nominal Package Size [mm]	Max Units		Reel & Hub Size [mm]	Leader (min)		Trailer (min)		Tape Width [mm]	Part Pitch [mm]
			per Reel	per Box		Pockets	Length [mm]	Pockets	Length [mm]		
STDFN 8L 1x1.6mm 0.4P FC Green	8	1.0 x 1.6 x 0.55	3,000	3,000	178 / 60	100	400	100	400	8	4

Carrier Tape Drawing and Dimensions

Package Type	Pocket BTM Length	Pocket BTM Width	Pocket Depth	Index Hole Pitch	Pocket Pitch	Index Hole Diameter	Index Hole to Tape Edge	Index Hole to Pocket Center	Tape Width
	A0	B0	K0	P0	P1	D0	E	F	W
STDFN 8L 1x1.6mm 0.4P FC Green	1.12	1.72	0.7	4	4	1.55	1.75	3.5	8

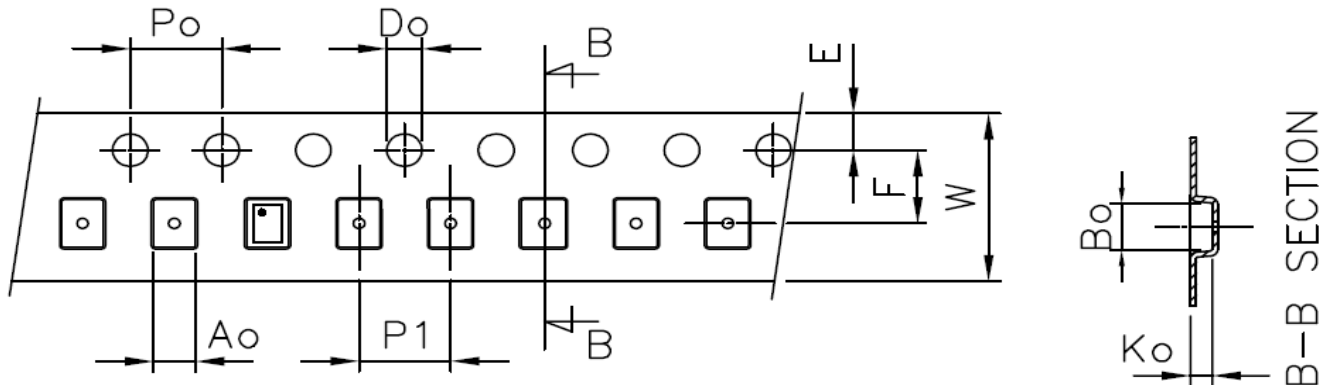

Recommended Reflow Soldering Profile

Please see IPC/JEDEC J-STD-020: latest revision for reflow profile based on package volume of 0.88 mm³ (nominal). More information can be found at www.jedec.org.

Revision History

Date	Version	Change
11/7/2019	1.02	Updated Style and Formatting Updated Abs. Max Table Added Layout Guidelines Fixed typos
9/1/2016	1.01	Updated Power Up/Down Sequencing Considerations Updated Current Limiting Description Updated text and parameter names for clarity