

## High Performance Digital Power Factor Correction Controller with Intelligent Standby Mode for AC/DC Power Supplies

### 1 Description

The iW2206-01 is a high-performance boost controller for AC/DC power supplies that need power factor correction. The device operates in transition mode and can support up to 150W of output power, features an intelligent standby mode to minimize quiescent power loss and is offered in a tiny SOT23-6 package.

The iW2206-01 tightly regulates the output DC bus voltage across AC line and load conditions. The advanced digital control eliminates the need for external loop compensation while maintaining excellent stability across all operating conditions.

The iW2206-01 can be set in standby mode by pulling VFB pin to GND. This minimize the power loss of system standby without need of cutting off  $V_{CC}$ . The iW2206-01 can recover from sleep mode within 200 $\mu$ s after releasing the VFB pin to ensure fast  $V_{BUS}$  regulation for 2<sup>nd</sup> stage converter and the output DC bus voltage level is user-configurable to support either “following AC input voltage” or “fixed” for different application needs.

The iW2206-01 also features various protections such as output over-voltage, over-power, AC over-voltage, AC under-voltage, current-sense-resistor short, over-current, loop-open and over-temperature protection. This ensures robust and reliable system performance.

### 2 Features

- Universal AC input voltage range  $85V_{AC} \sim 265V_{AC}$
- Supports up to 150W output power
- Smart standby mode minimizes quiescent power draw to < 150mW and saves BOM cost (stand-alone operation)
  - » System level standby power (see figure 3.2) even lower with iW2206-01 disabled
- Advanced digital control loop achieves best transient and optimizes bulk capacitance requirement
- Accurate over-power protection, <  $\pm 10\%$  across full AC range
- AC line and load regulation <  $\pm 3\%$
- Fast PFC ready time < 0.2s
- Space-saving SOT23-6 package eases PCB layout
- Configurable output DC bus voltage
- Wide operating supply voltage ( $V_{VCC}$ ) range from 8.0V to 20V
- Comprehensive protection features
  - » Output over-voltage protection
  - » AC over-voltage protection
  - » AC under-voltage protection (Brown-out)
  - » Cycle-by-cycle peak current limit
  - » Loop-open protection
  - » Current-sense-resistor short protection
  - » Over-temperature protection

### 3 Applications

- Two-stage adapters
- AC/DC power supplies

# iW2206-01

## High Performance Digital Power Factor Correction Controller with Intelligent Standby Mode for AC/DC Power Supplies

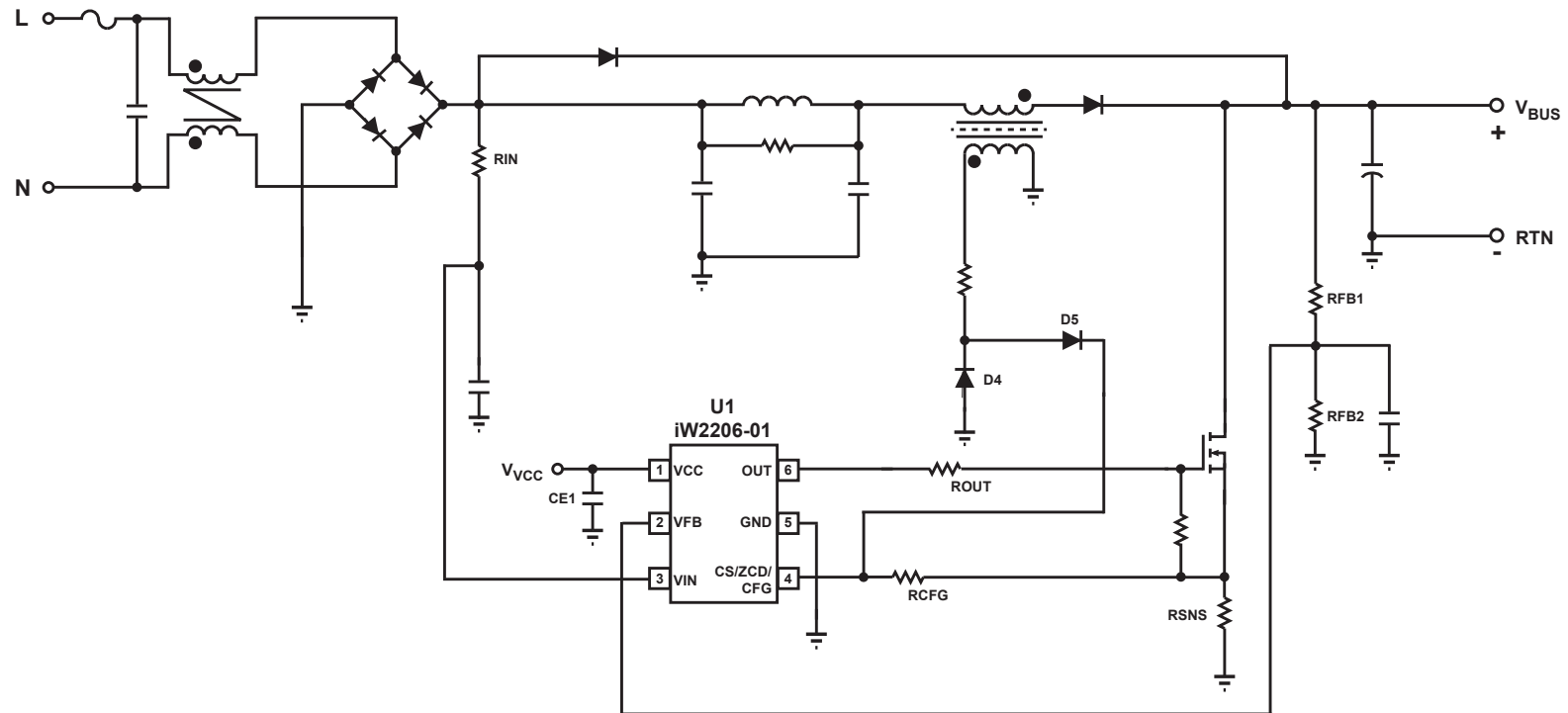

Figure 3.1 : iW2206-01 PFC Boost Typical Application Circuit.

# iW2206-01

## High Performance Digital Power Factor Correction Controller with Intelligent Standby Mode for AC/DC Power Supplies

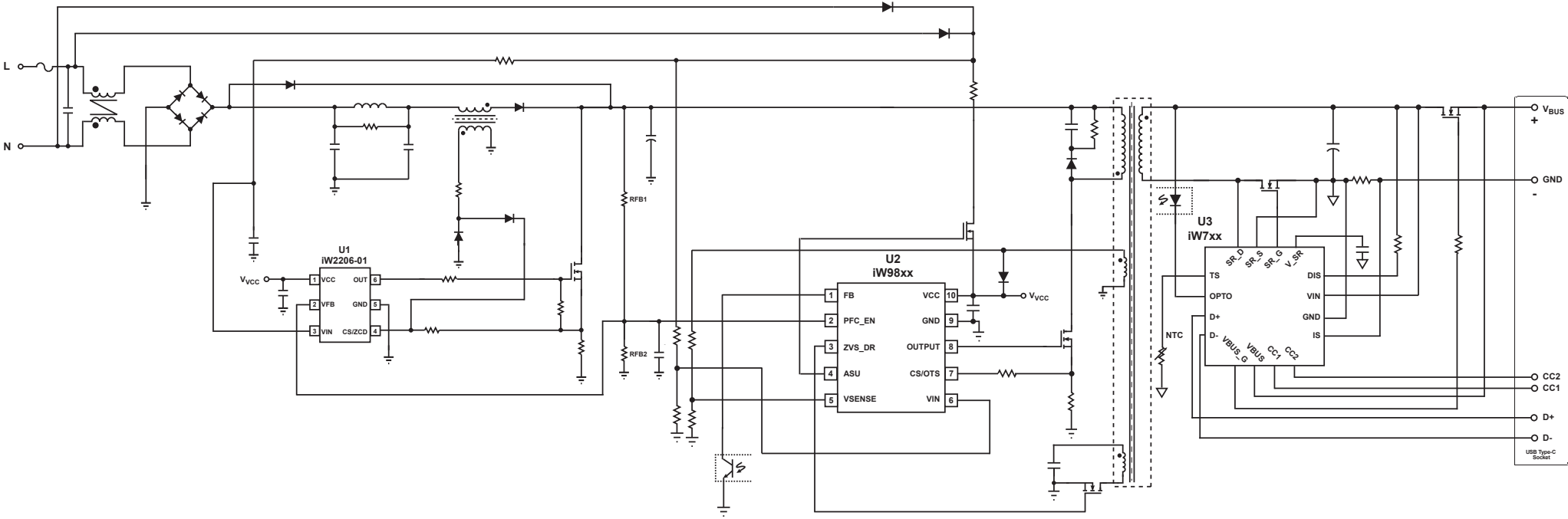

Figure 3.2 : iW2206-01 PFC Boost with USB PD Charging Circuit (iW98xx as Primary-Side Controller and iW7xx as Synchronous Rectification and Protocol Interface Controller).

## High Performance Digital Power Factor Correction Controller with Intelligent Standby Mode for AC/DC Power Supplies

### 4 Pinout Description

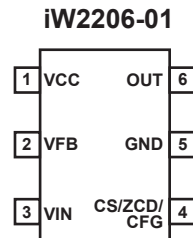

Figure 4.1 : 6-Lead SOT23 Package

Pin Number	Pin Name	Type	Pin Description
1	VCC	Power Input	IC power supply.
2	VFB	Analog Input	Output DC bus voltage sense.
3	VIN	Analog Input	Input AC line voltage sense.
4	CS/ZCD/CFG	Analog Input	Power MOSFET current sense, inductor reset sense and configuration.
5	GND	Ground	Ground reference.
6	OUTPUT	Analog Output	Power MOSFET gate drive.

## High Performance Digital Power Factor Correction Controller with Intelligent Standby Mode for AC/DC Power Supplies

### 5 Absolute Maximum Ratings

Absolute maximum ratings are the parameter values or ranges which can cause permanent damage if exceeded. For maximum safe operating conditions, refer to Electrical Characteristics in Section 6.

Parameter	Symbol	Value	Units
DC supply voltage range (pin 1, $I_{VCC} = 20\text{mA max}$ )	$V_{VCC}$	-0.3 to 22.0	V
Continuous DC supply current at VCC pin ( $V_{VCC} = 15\text{V}$ )	$I_{VCC}$	20	mA
$V_{VIN}$ (pin 3)		-0.3 to 20.0	V
OUTPUT (pin 6)		-0.3 to 20.0	V
$V_{VFB}$ (pin 2, $I_{FB} \leq 10\text{mA}$ )		-0.7 to 5.0	V
CS/ZCD/CFG input (pin 4)		-0.3 to 5.0	V
Maximum junction temperature	$T_{JMAX}$	150	°C
Operating junction temperature	$T_{JOPT}$	-40 to 150	°C
Storage temperature	$T_{STG}$	-65 to 150	°C
Thermal resistance junction-to-ambient	$\theta_{JA}$	190	°C/W
ESD rating per JEDEC JS-001-2017		±2,000	V
Latch-up test per JESD78E		±100	mA

**High Performance Digital Power Factor Correction Controller with Intelligent Standby Mode for AC/DC Power Supplies**

**6 Physical Dimensions**

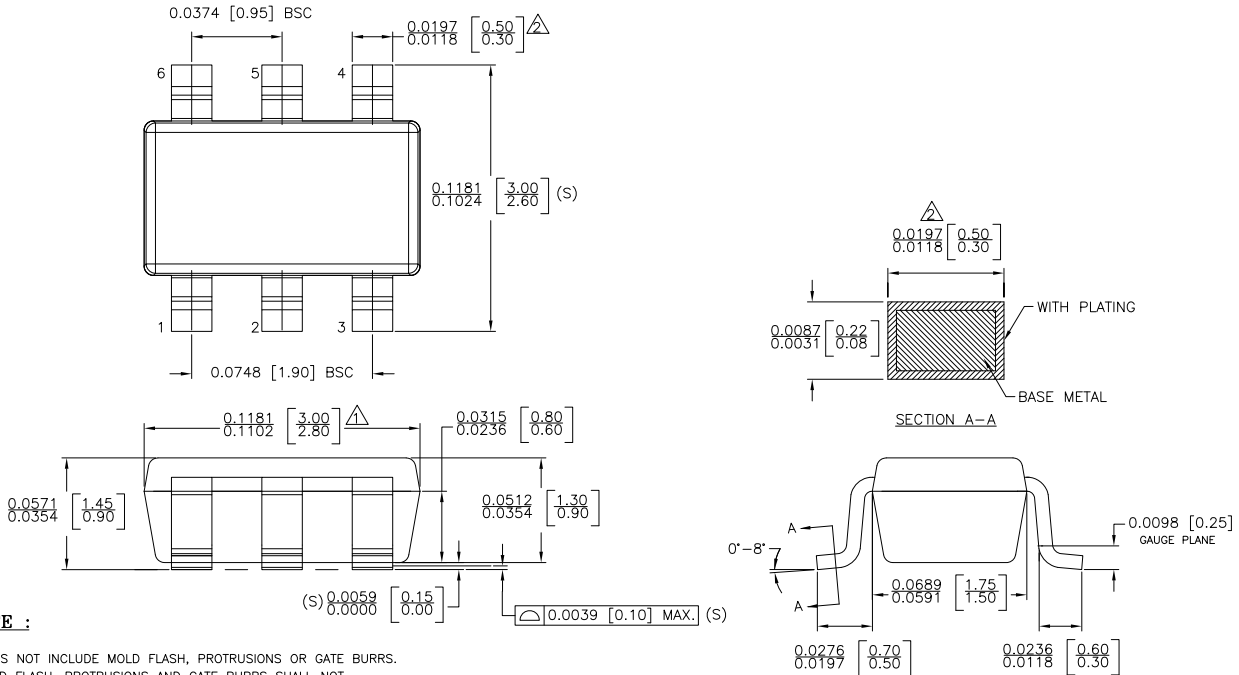

**NOTE :**

- △ DOES NOT INCLUDE MOLD FLASH, PROTRUSIONS OR GATE BURRS. MOLD FLASH, PROTRUSIONS AND GATE BURRS SHALL NOT EXCEED 0.127 MM PER SIDE.
- △ DOES NOT INCLUDE INTER-LEAD FLASH OR PROTRUSIONS. INTER-LEAD FLASH AND PROTRUSIONS SHALL NOT EXCEED 0.127 MM PER SIDE.
- 3. DIE IS FACING UP FOR MOLD. DIE IS FACING DOWN FOR TRIM/FORM.
- 4. THIS PART IS COMPLIANT WITH EIAJ SPECIFICATION SC74A AND JEDEC SPECIFICATION MO-178AB.
- 5. LEAD SPAN/STAND OFF HEIGHT/COPLANARITY ARE CONSIDERED AS SPECIAL CHARACTERISTIC(S).
- 6. CONTROLLING DIMENSIONS IN INCHES. [mm]

STATUS: RELEASED	SCALE: DO NOT SCALE	
TERMINAL FINISH: 100% Sn or NiPdAu (PPF)		
TITLE: 6 SOT23 PACKAGE OUTLINE		
REV: A	REVISION NOTE: NEW DRAWING	DATE: 02-MAR-2015

**7 Ordering Information**

Part Number	Description	Package	Description
iW2206-01	Power factor correction controller optimized for gate driver with bipolar PNP pull down	SOT-23	Tape & Reel <sup>1</sup>

Note 1: Tape & Reel packing quantity is 3,000/reel. Minimum packing quantity is 3,000.

## High Performance Digital Power Factor Correction Controller with Intelligent Standby Mode for AC/DC Power Supplies

### Disclaimer

Unless otherwise agreed in writing, the Dialog Semiconductor products (and any associated software) referred to in this document are not designed, authorized or warranted to be suitable for use in life support, life-critical or safety-critical systems or equipment, nor in applications where failure or malfunction of a Dialog Semiconductor product (or associated software) can reasonably be expected to result in personal injury, death or severe property or environmental damage. Dialog Semiconductor and its suppliers accept no liability for inclusion and/or use of Dialog Semiconductor products (and any associated software) in such equipment or applications and therefore such inclusion and/or use is at the customer's own risk.

Information in this document is believed to be accurate and reliable. However, Dialog Semiconductor does not give any representations or warranties, express or implied, as to the accuracy or completeness of such information. Dialog Semiconductor furthermore takes no responsibility whatsoever for the content in this document if provided by any information source outside of Dialog Semiconductor.

Dialog Semiconductor reserves the right to change without notice the information published in this document, including, without limitation, the specification and the design of the related semiconductor products, software and applications. Notwithstanding the foregoing, for any automotive grade version of the device, Dialog Semiconductor reserves the right to change the information published in this document, including, without limitation, the specification and the design of the related semiconductor products, software and applications, in accordance with its standard automotive change notification process.

Applications, software, and semiconductor products described in this document are for illustrative purposes only. Dialog Semiconductor makes no representation or warranty that such applications, software and semiconductor products will be suitable for the specified use without further testing or modification. Unless otherwise agreed in writing, such testing or modification is the sole responsibility of the customer and Dialog Semiconductor excludes all liability in this respect.

Nothing in this document may be construed as a license for customer to use the Dialog Semiconductor products, software and applications referred to in this document. Such license must be separately sought by customer with Dialog Semiconductor.

All use of Dialog Semiconductor products, software and applications referred to in this document is subject to Dialog Semiconductor's [Standard Terms and Conditions of Sale](#), available on the company website ([www.dialog-semiconductor.com](http://www.dialog-semiconductor.com)) unless otherwise stated.

Dialog, Dialog Semiconductor and the Dialog logo are trademarks of Dialog Semiconductor Plc or its subsidiaries. All other product or service names and marks are the property of their respective owners.

© 2020 Dialog Semiconductor. All rights reserved.

### RoHS Compliance

Dialog Semiconductor's suppliers certify that its products are in compliance with the requirements of Directive 2011/65/EU of the European Parliament on the restriction of the use of certain hazardous substances in electrical and electronic equipment. RoHS certificates from our suppliers are available on request.

## Contacting Dialog Semiconductor

**United Kingdom (Headquarters)**  
Dialog Semiconductor (UK) LTD  
Phone: +44 1793 757700

**Germany**  
Dialog Semiconductor GmbH  
Phone: +49 7021 805-0

**The Netherlands**  
Dialog Semiconductor B.V.  
Phone: +31 73 640 8822

**Email**  
[info\\_pcbg@diasemi.com](mailto:info_pcbg@diasemi.com)

**North America**  
Dialog Semiconductor Inc.  
Phone: +1 408 845 8500

**Japan**  
Dialog Semiconductor K. K.  
Phone: +81 3 5769 5100

**Taiwan**  
Dialog Semiconductor Taiwan  
Phone: +886 281 786 222

**Web site:**  
[www.dialog-semiconductor.com](http://www.dialog-semiconductor.com)

**Hong Kong**  
Dialog Semiconductor Hong Kong  
Phone: +852 2607 4271

**Korea**  
Dialog Semiconductor Korea  
Phone: +82 2 3469 8200

**China (Shenzhen)**  
Dialog Semiconductor China  
Phone: +86 755 2981 3669

**China (Shanghai)**  
Dialog Semiconductor China  
Phone: +86 21 5424 9058