

REV	WHEN	WHO	WHAT
A0	April, 2011	TN	Initial version based on DA6011CA_REFERENCE_DESIGN_E6xx_A7.sch

Dialog Semiconductor Inc.

**Note:**

In case of ATX supply connect VDD\_1 to +5VSB  
and VDD\_2 to +5VDC of external ATX supply

if no external ATX supply is present please connect  
VDD\_1 and VDD\_2 to external supply voltage

Please also check latest FAQ document for details regarding ATX supply

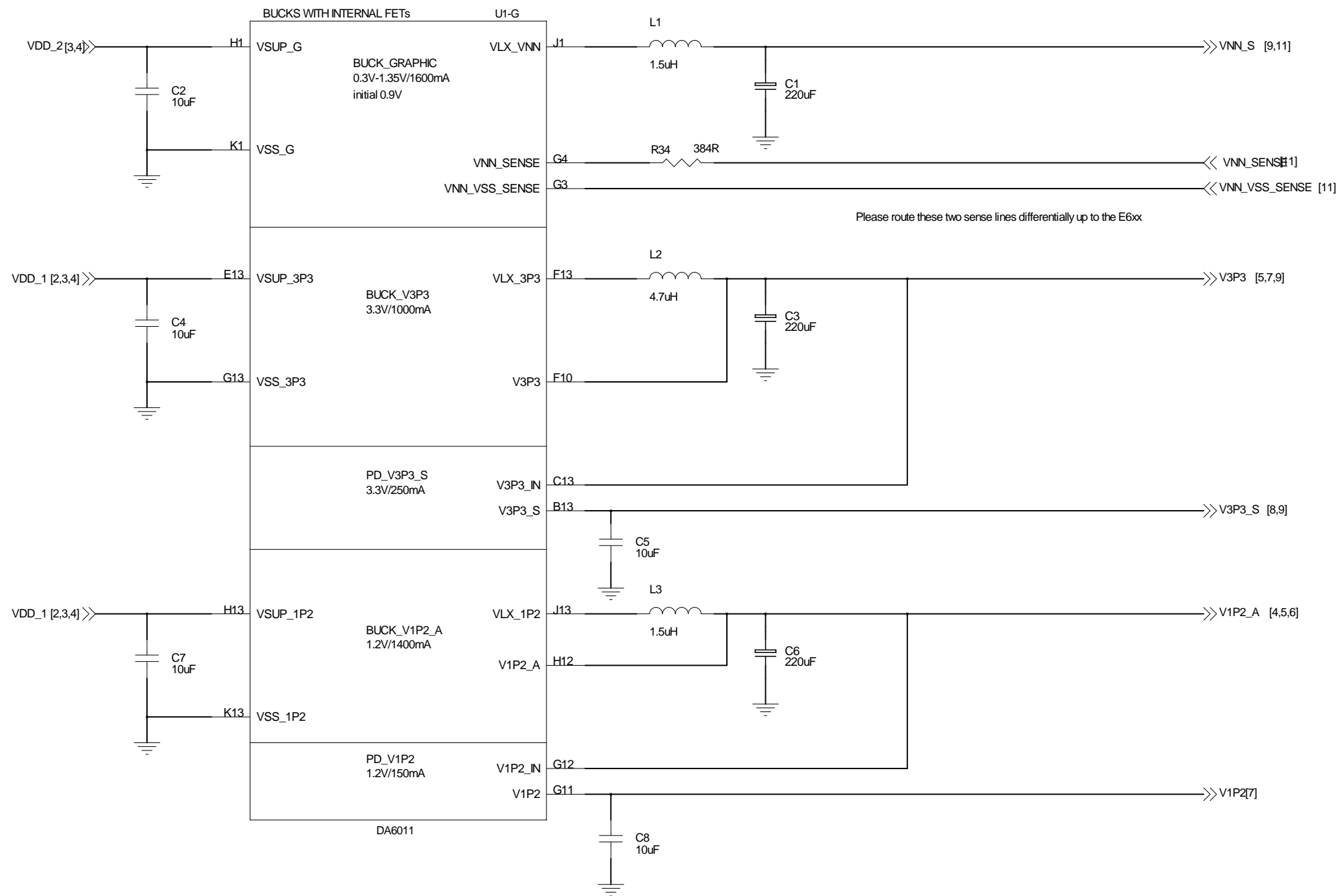

Dialog Semiconductor Inc.

