

Application Note

PWM Control for PC Fans

AN-CM-248

Abstract

This Application Note details how Dialog Semiconductor built a fully-featured 12 V PC fan PWM controller with Dialog GreenPAK™ configurable mixed-signal ICs. The project involves rotary encoding, PWM control, PCB design, and C# application programming.

This document is complimented by design files, which are listed in the References section.

PWM Control for PC Fans

Contents

Abstract	1
Contents	2
Figures	2
Tables	3
1 Terms and Definitions	4
2 References	4
3 Introduction	5
3.1 System Block Diagram.....	5
4 SLG46108 Rotary Decoder Design	6
5 SLG46826 Fan Controller Design	8
5.1 PWM Generation with Offset Counters.....	8
5.2 Duty Cycle Control with Clock Injection and Clock Skipping.....	9
5.2.1 BUTTON Input.....	10
5.2.2 Preventing Duty Cycle Rollover.....	10
5.3 Duty Cycle Control with I ² C.....	12
5.4 Tachometer Reading.....	13
6 External Circuit Design	14
7 PCB Design	15
8 C# Application	15
9 Conclusions	16
Revision History	17

Figures

Figure 1. System Block Diagram.....	5
Figure 2. Rotary Encoder Block Diagram.....	6
Figure 3. GreenPAK SLG46108 Rotary Decoder Design.....	7
Figure 4. Timing Diagram of Rotary Signals.....	7
Figure 5. GreenPAK SLG46826 Fan Controller Design.....	8
Figure 6. PWM Generation Timing Diagram.....	8
Figure 7. PWM Generation with Offset Counters.....	8
Figure 8. Clock Pulse Injection.....	9
Figure 9. Clock Pulse Skipping.....	9
Figure 10. Clock Skipping and Clock Injecting.....	10
Figure 11. BLOCK_CW and BLOCK_CCW.....	10
Figure 12. Minimum Duty Cycle Rollover Case.....	11
Figure 13. Maximum Duty Cycle Rollover Case.....	11
Figure 14. I ² C Control of Duty Cycle.....	12
Figure 15. Loading the Duty Cycle with I ² C (frequencies are not to scale).....	13
Figure 16. Tachometer Section.....	13
Figure 17. Fan Controller Block Diagram.....	14
Figure 18. PCBs and Connectors.....	15
Figure 19. C# Application GUI.....	15

PWM Control for PC Fans

Tables

Table 1: Duty Cycle I ² C Commands	12
Table 2: Tachometer I ² C Commands.....	13

PWM Control for PC Fans

1 Terms and Definitions

CCW	Counterclockwise
CW	Clockwise
I ² C	Inter-integrated circuit
PCB	Printed circuit board
PWM	Pulse width modulation

2 References

For related documents and software, please visit:

<https://www.dialog-semiconductor.com/configurable-mixed-signal>.

Download our free **GreenPAK** Designer software [1] to open the .gp files [2] and view the proposed circuit design. Use the **GreenPAK** development tools [3] to freeze the design into your own customized IC in a matter of minutes. Dialog Semiconductor provides a complete library of application notes [4] featuring design examples as well as explanations of features and blocks within the Dialog IC.

- [1] [GreenPAK Designer Software](#), Software Download and User Guide, Dialog Semiconductor
- [2] [AN-CM-248 PWM Controller for PC Fans.gp](#), [GreenPAK Design File](#), Dialog Semiconductor
- [3] [GreenPAK Development Tools](#), [GreenPAK Development Tools Webpage](#), Dialog Semiconductor
- [4] [GreenPAK Application Notes](#), [GreenPAK Application Notes Webpage](#), Dialog Semiconductor
- [5] SLG46108, <https://www.dialog-semiconductor.com/products/slg46108>, Dialog Semiconductor
- [6] SLG46826, <https://www.dialog-semiconductor.com/products/slg46826>, Dialog Semiconductor
- [7] AN-1101 Unclocked Quadrature Decoder, <https://www.dialog-semiconductor.com/greenpak-application-notes?combine=1101>, Dialog Semiconductor
- [8] DMP3085LSD-13DICT-ND, <https://www.digikey.com/product-detail/en/diodes-incorporated/DMP3085LSD-13/DMP3085LSD-13DICT-ND/4251594>, Diodes Incorporated
- [9] QS5K2CT-ND, <https://www.digikey.com/product-detail/en/rohm-semiconductor/QS5K2TR/QS5K2CT-ND/1144089>, Rohm Semiconductor

PWM Control for PC Fans

3 Introduction

This document describes building a fully-featured 12 V PC fan PWM controller. The design can control up to 16 3-pin computer fans. The design uses a pair of Dialog **GreenPAK™** configurable mixed-signal ICs to control each fan's duty cycle. It also includes two ways to change the speed of the fan:

- a. with a quadrature/rotary encoder
- b. with a Windows application built in C# that communicates with the **GreenPAKs** through I²C.

3.1 System Block Diagram

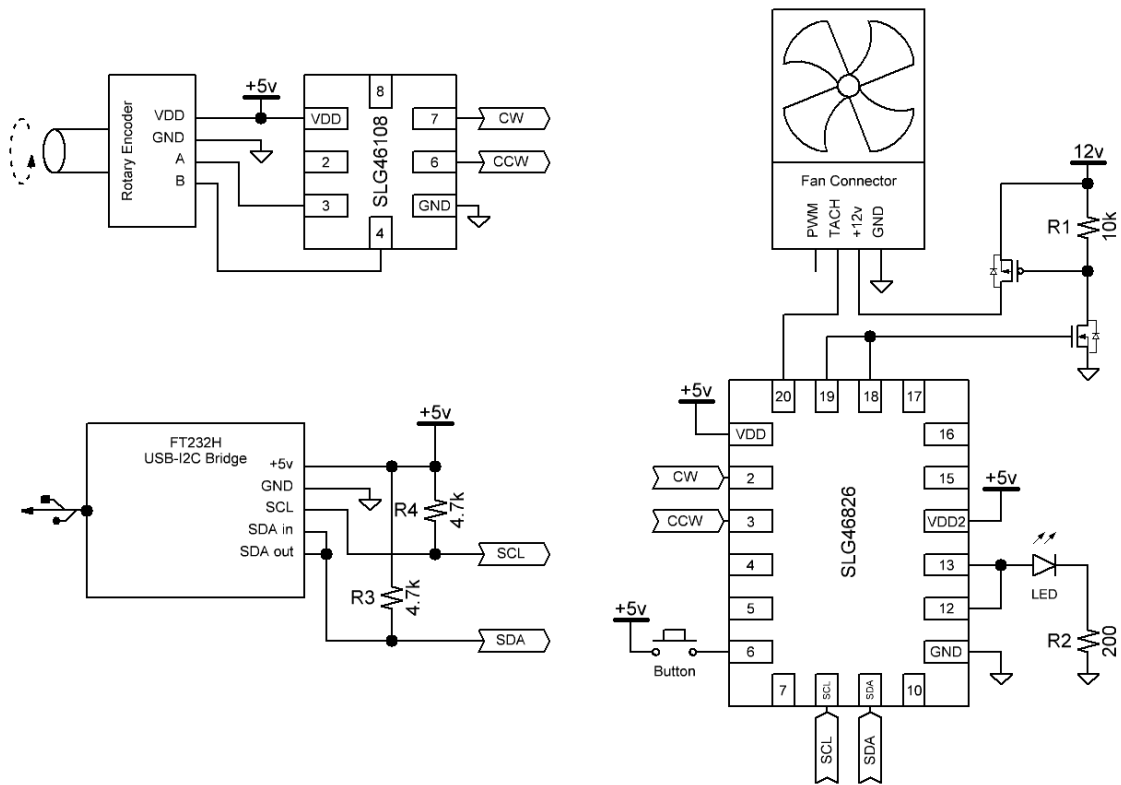

Figure 1. System Block Diagram

PWM Control for PC Fans

4 SLG46108 Rotary Decoder Design

A rotary encoder is used to increase or decrease the duty cycle of the fans manually. This device outputs pulses on its Channel A and Channel B outputs that are 90 ° apart. See [AN-1101: Unlocked Quadrature Decoder](#) [7] for more information about how a rotary encoder works.

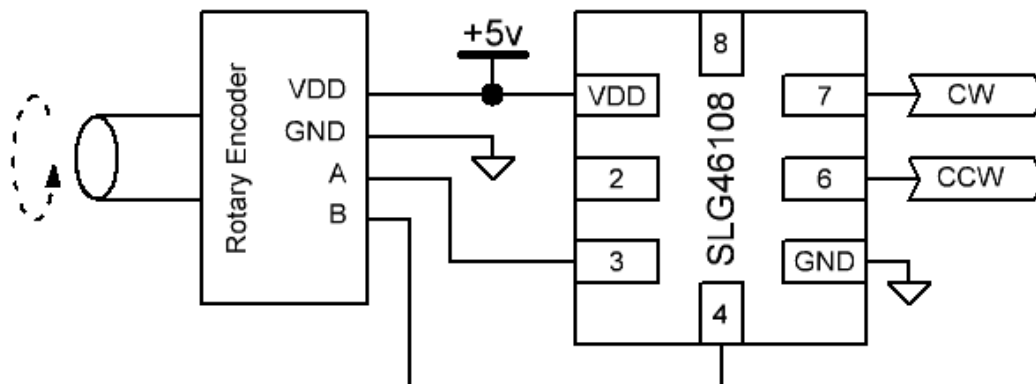

Figure 2: Rotary Encoder Block Diagram

A clocked rotary decoder can be created using a Dialog [GreenPAK](#) SLG46108 to process the Channel A and Channel B signals and output them as counterclockwise (CCW) and clockwise (CW) pulses.

When Channel A leads Channel B, the design outputs a short pulse on CW. When Channel B leads Channel A, it outputs a short pulse on CCW.

PWM Control for PC Fans

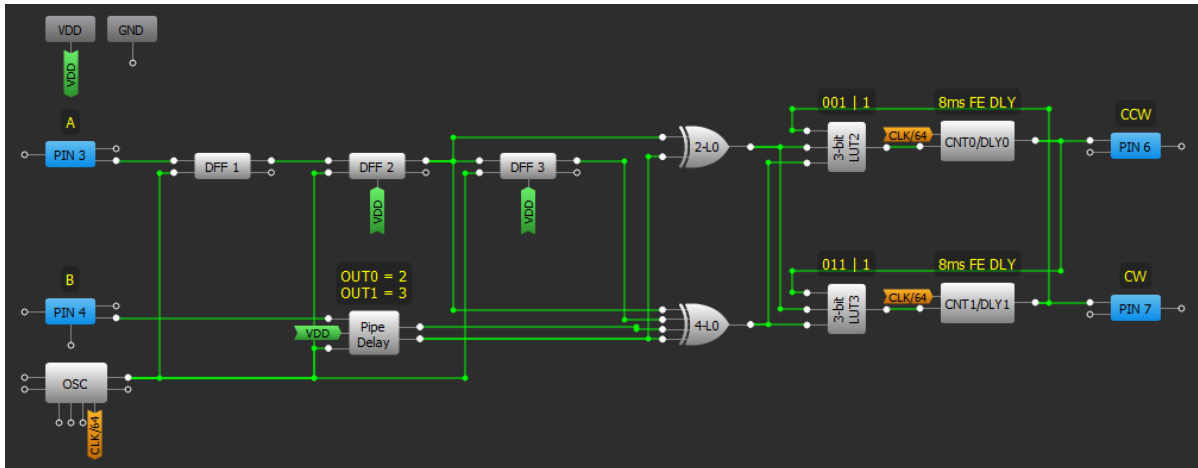

Figure 3. GreenPAK SLG46108 Rotary Decoder Design

Three DFFs synchronize the Channel A input with the clock. Similarly, the pipe delay with OUT0 set to two DFFs and OUT1 set to three DFFs create the same functionality for channel B.

To create CW and CCW outputs use a few LUTs, for more information about this standard rotary decoder design, visit [this website](#).

The GreenPAK Rotary Decoder will receive input pulses A and B and output the CW and CCW pulses as shown in Figure 4.

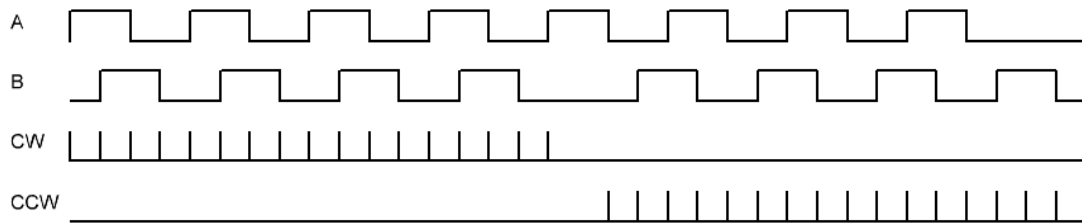

Figure 4. Timing Diagram of Rotary Signals

The circuitry after the XOR gates ensures that there will never be a CW pulse and CCW pulse at the same time, allowing for any error with the rotary encoder. The 8 ms falling edge delay on the CW and CCW signals force them to stay high for 8 ms plus one clock cycle, which is necessary for the downstream SLG46826 GreenPAKs.

5 SLG46826 Fan Controller Design

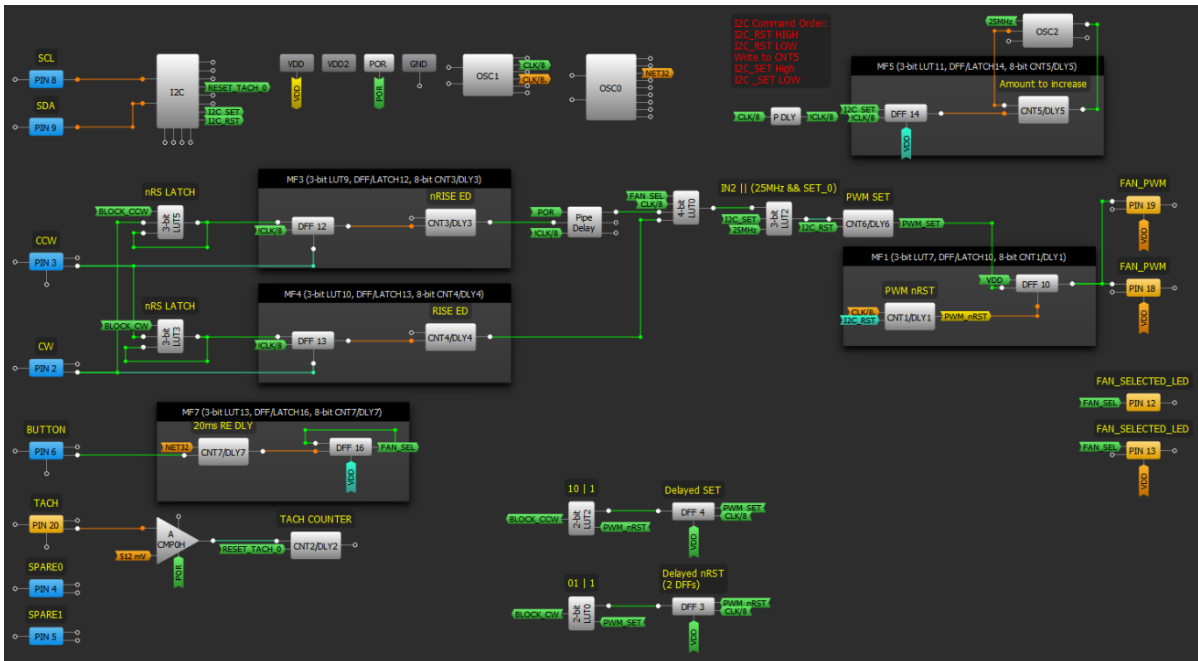

Figure 5. GreenPAK SLG46826 Fan Controller Design

5.1 PWM Generation with Offset Counters

A pair of offset counters with the same period are used to generate the PWM signal. The first counter sets a DFF, and the second resets it, creating a consistent duty cycle PWM signal as shown in Figure 6 and Figure 7.

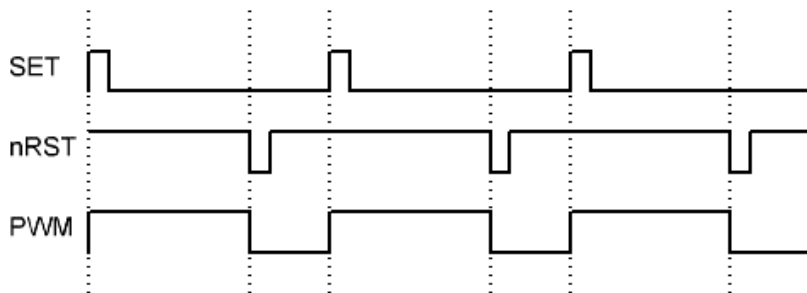

Figure 6. PWM Generation Timing Diagram

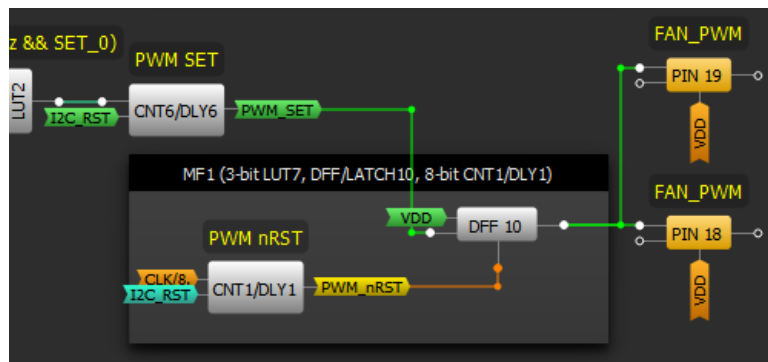

Figure 7. PWM Generation with Offset Counters

PWM Control for PC Fans

CNT6 sets DFF10 and the inverted output of CNT1 resets DFF10. Pins 18 and 19 are used to output the PWM signal to external circuitry.

5.2 Duty Cycle Control with Clock Injection and Clock Skipping

The fan controller receives the CW and CCW signals as inputs from the rotary decoder and uses them to either increase or decrease the PWM signal that controls the fan speed. This is achieved with several digital logic components.

The duty cycle needs to increase when a CW pulse is received. This is done by injecting an extra clock pulse into the CNT6 block, causing it to output one clock cycle earlier than it otherwise would have. This process is shown in [Figure 8](#).

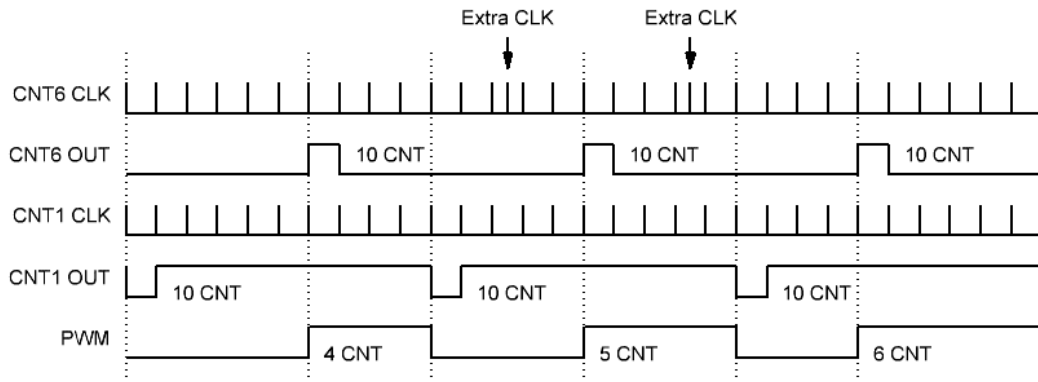

Figure 8. Clock Pulse Injection

CNT1 is still getting clocked at a constant rate, but CNT6 has a couple of extra clocks injected. Every time there is an extra clock to the counter, it shifts its output one clock period to the left.

Conversely, to decrease the duty cycle, skip a clock pulse for CNT6 as shown in [Figure 9](#). CNT1 is still getting clocked at a constant rate, and there are skipped clock pulses for CNT6, where the counter did not get clocked when it was supposed to. This way the output of CNT6 is pushed to the right by one clock period at a time, shortening the output PWM duty cycle.

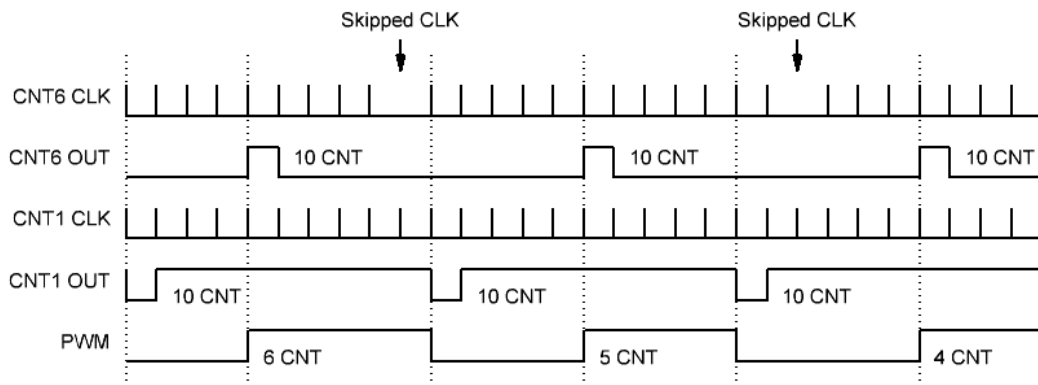

Figure 9. Clock Pulse Skipping

The clock injecting and clock skipping functionality is performed with use of some digital logic elements within the [GreenPAK](#). A pair of multifunction blocks are used to create a pair of latch/edge detector combos. 4-bit LUT0 is used to mux between the general clock signal (CLK/8) and the clock injecting or clock skipping signals. This functionality is described in more detail in [Section 5.2.2](#).

PWM Control for PC Fans

5.2.1 BUTTON Input

The BUTTON input is debounced for 20 ms, then used to toggle a latch that determines whether this particular chip is selected. If it is selected, then the 4-bit LUT passes the clock skipping or injection signals. If the chip is not selected, then the 4-bit LUT simply passes the CLK/8 signal.

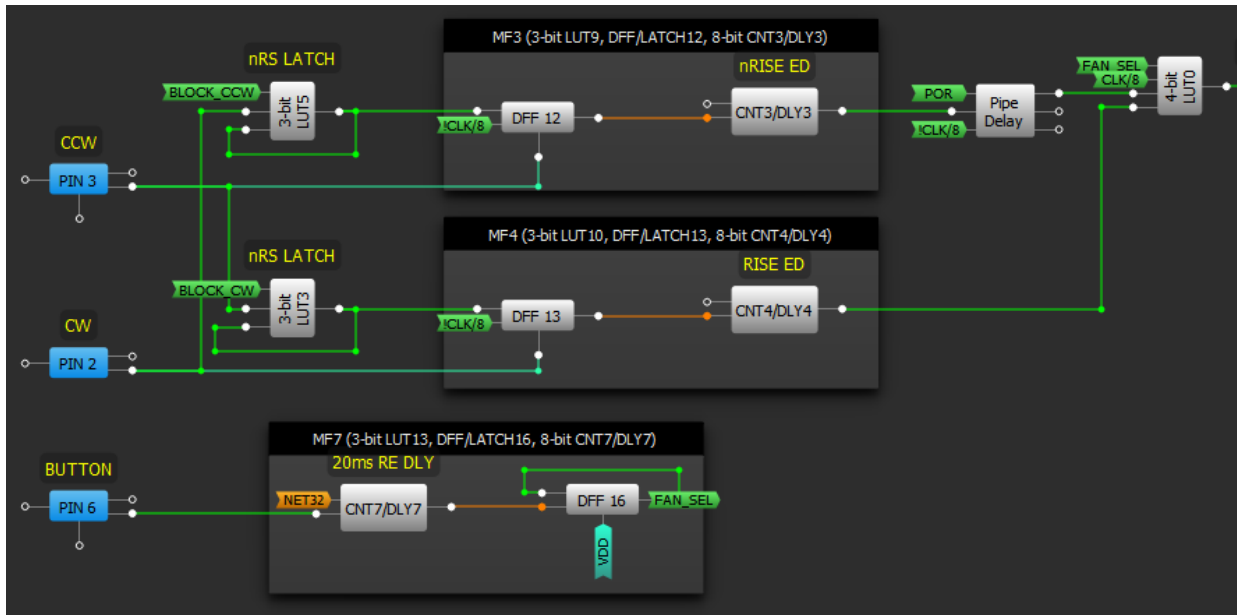

Figure 10. Clock Skipping and Clock Injecting

5.2.2 Preventing Duty Cycle Rollover

The RS latches 3-bit LUT5 and 3-bit LUT3 are used to make sure that you cannot inject or skip so many clocks that the offset counters roll over. This is to avoid the system reaching 100 % duty cycle and then rolling over to a 1 % duty cycle if it receives another injected clock.

The RS latches prevent this from happening by latching the inputs to the multifunction blocks when the system is one clock cycle away from rolling over. A pair of DFFs delay the PWM_SET and PWM_nRST signals by one clock period as shown in Figure 11.

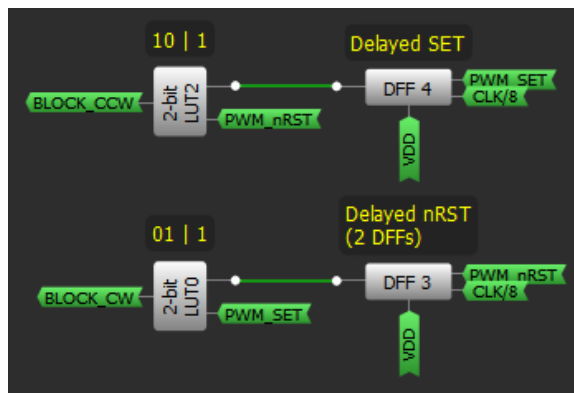

Figure 11. BLOCK_CW and BLOCK_CCW

A pair of LUTs are used to create the necessary logic. If the duty cycle is so low that the delayed PWM_SET signal occurs at the same time as the PWM_nRST signal, a further decrease in the duty cycle will cause a rollover.

PWM Control for PC Fans

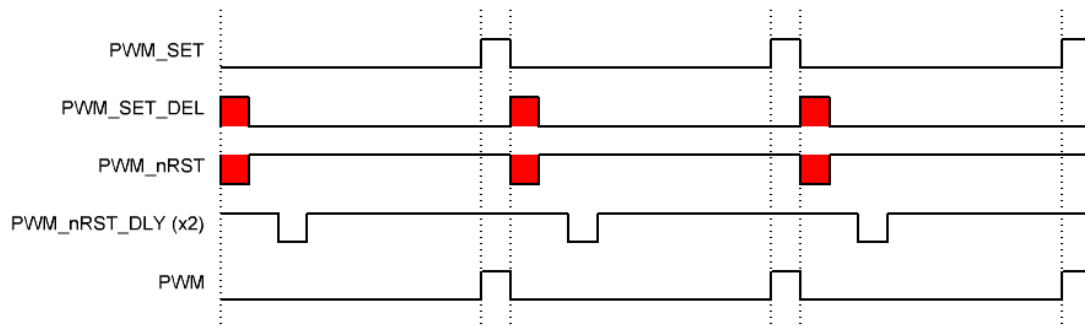

Figure 12. Minimum Duty Cycle Rollover Case

Similarly, if approaching maximum duty cycle, such that the delayed PWM_nRST signal occurs at the same time as the PWM_SET signal, it is necessary to avoid any further increase to the duty cycle. In this instance, delay the nRST signal by two clock cycles to ensure that the system does not roll over from 99 % to 1 %.

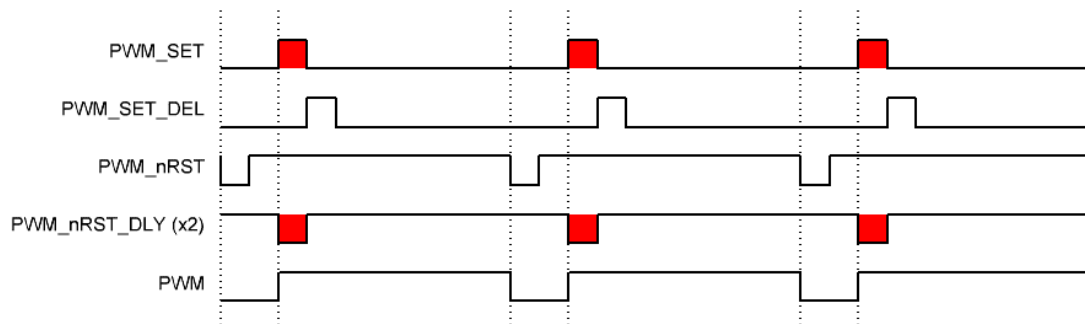

Figure 13. Maximum Duty Cycle Rollover Case

PWM Control for PC Fans

5.3 Duty Cycle Control with I²C

This design incorporates another way to control the duty cycle other than clock skipping/clock injecting. An external microcontroller can be used to write I²C commands to the GreenPAK to set the duty cycle.

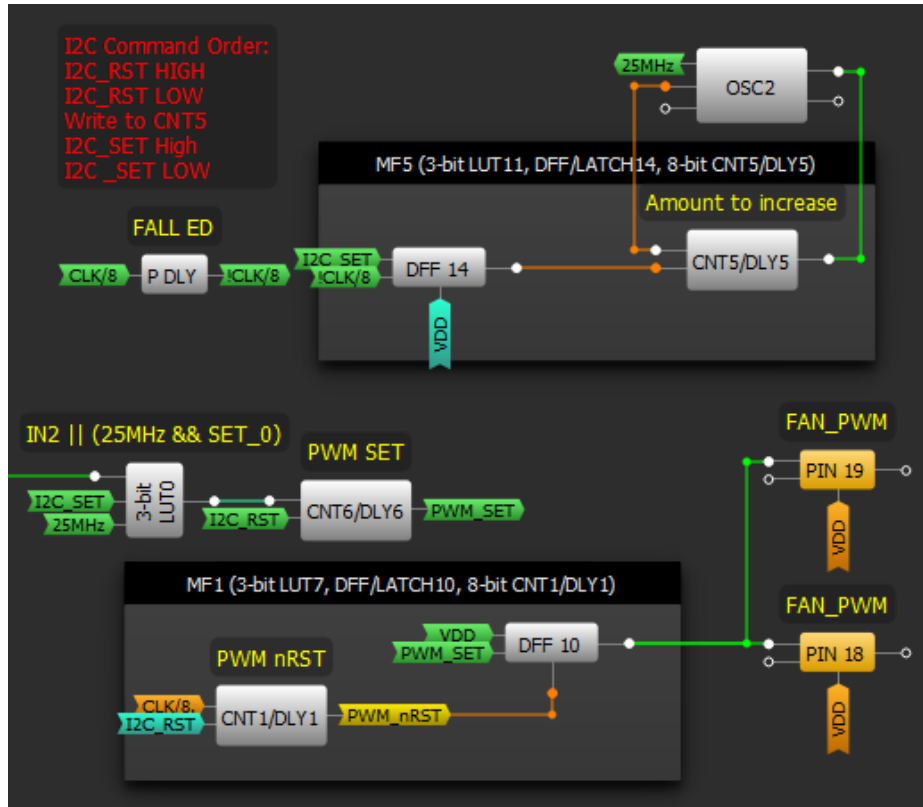

Figure 14. I²C Control of Duty Cycle

Controlling the duty cycle over I²C requires the controller to perform a specific command sequence. These commands are shown in order in Table 1. An "x" indicates a bit that should not change, "[" indicates a START bit, and "]" indicates a STOP bit.

Table 1: Duty Cycle I²C Commands

Desired Function	I ² C Command (with slave address of 0001)	Purpose
Set I2C_RST HIGH	[0x10 0x7A xxxx xxx1]	Reset CNT6 and CNT1 at the same time so that their outputs are synchronized
Set I2C_RST LOW	[0x10 0x7A xxxx xxx0]	Release the reset on CNT6 and CNT1 so that they start counting
Write to CNT5	[0x10 0xBC (0-255)]	Load the OneShot pulse with the desired amount to increase the duty cycle
Set I2C_SET HIGH	[0x10 0x7A xxxx xx1x]	Start the CNT5 OneShot pulse on the next falling edge of CLK/8
Set I2C_SET LOW	[0x10 0x7A xxxx xx0x]	Reset the I2C_SET signal to LOW

The PDLY block generates a short active high pulse on the falling edge of the CLK/8 signal, which is called !CLK/8. That signal is used to clock DFF14 at a steady frequency. When I2C_SET goes high asynchronously, the next rising edge of !CLK/8 causes DFF14 to output HIGH, which triggers the CNT5 OneShot. The OneShot runs for the number of clock cycles that the user wrote as specified in the "Write to CNT5" I²C command in Table 1. In this case, it is 10 clock cycles. The OneShot allows

PWM Control for PC Fans

the 25 MHz oscillator to run for exactly its duration and no longer, so that 3-bit LUT0 receives the number of clock cycles that were written to CNT5.

Figure 15 shows these signals, where the red clocks are the ones that are sent to 3-bit LUT0, which passes them into CNT6 (the PWM_SET counter), thus creating the offset for the duty cycle generation.

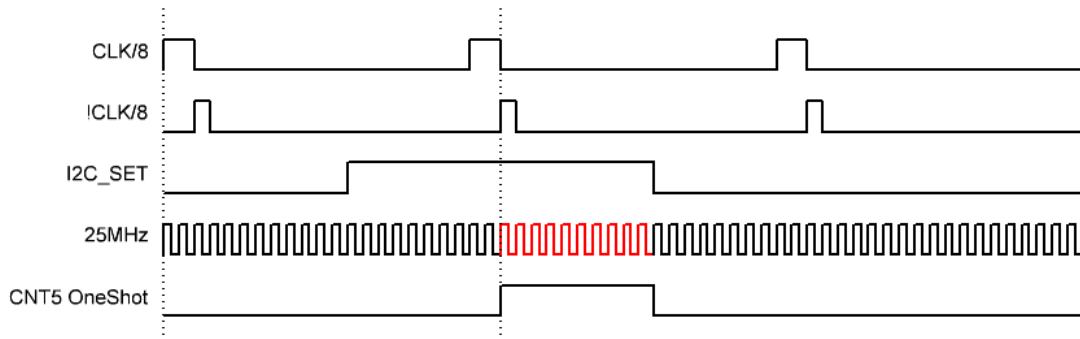

Figure 15. Loading the Duty Cycle with I²C (frequencies are not to scale)

5.4 Tachometer Reading

If desired, the user can read the tachometer value over I²C to track how quickly the fan is turning by reading the CNT2 value. CNT2 is incremented every time ACMP0H has a rising edge, and can be asynchronously reset with an I²C command. Note that this is an optional feature, and the threshold of ACMP0H will need to be tweaked according to the specifications of the particular fan being used.

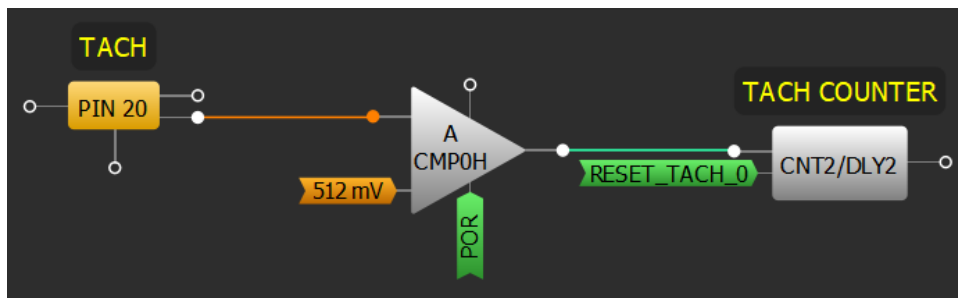

Figure 16. Tachometer Section

Table 2: Tachometer I²C Commands

Desired Function	I ² C Command (with slave address of 0001)	Purpose
Read TACH COUNTER	[0x10 0x7E [0x11 r	Read the value in CNT2
Reset TACH COUNTER	[0x10 0x7A xxx1 xxxx]	Reset the value in CNT2
Un-reset TACH Counter	[0x10 0x7A xxx0 xxxx]	Release the reset on CNT2 so that it starts counting

PWM Control for PC Fans

6 External Circuit Design

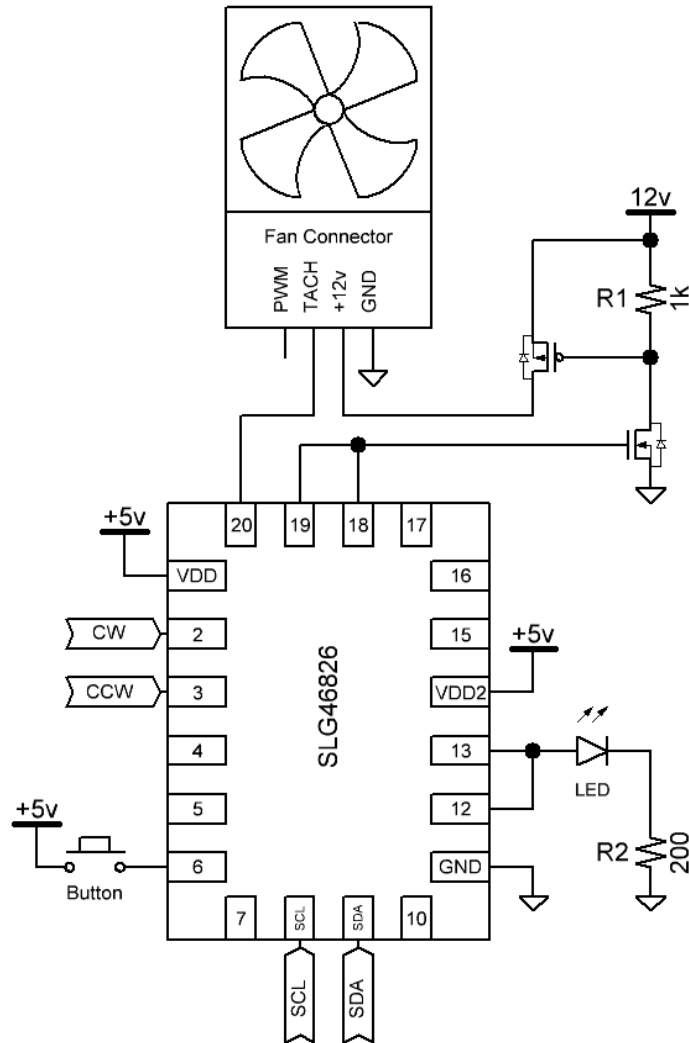

Figure 17. Fan Controller Block Diagram

The external circuit is fairly simple. There is a pushbutton connected to Pin6 of the GreenPAK to toggle whether this particular device is selected for rotary control, and an LED connected to Pin12 and Pin13 to indicate when the device is selected.

Since the fan runs off 12 V, a pair of FETs to control its switching is required. The GreenPAK's Pin18 and Pin19 drive an nFET. When the nFET is turned on, it pulls the gate of the pFET LOW, which connects the fan to +12 V. When the nFET is turned off, the gate of the PFET is pulled up by the 1 kΩ resistor, which disconnects the fan from +12 V.

7 PCB Design

To prototype the design a couple of PCBs were assembled. The PCB on the left is the "Fan Controller," which houses the rotary encoder, 12 V jack, SLG46108 GreenPAK, and connectors for the FT232H USB to I²C breakout board. The two PCBs on the right are "Fan Boards," which contain the SLG46826 GreenPAKs, pushbuttons, switches, LEDs, and fan headers.

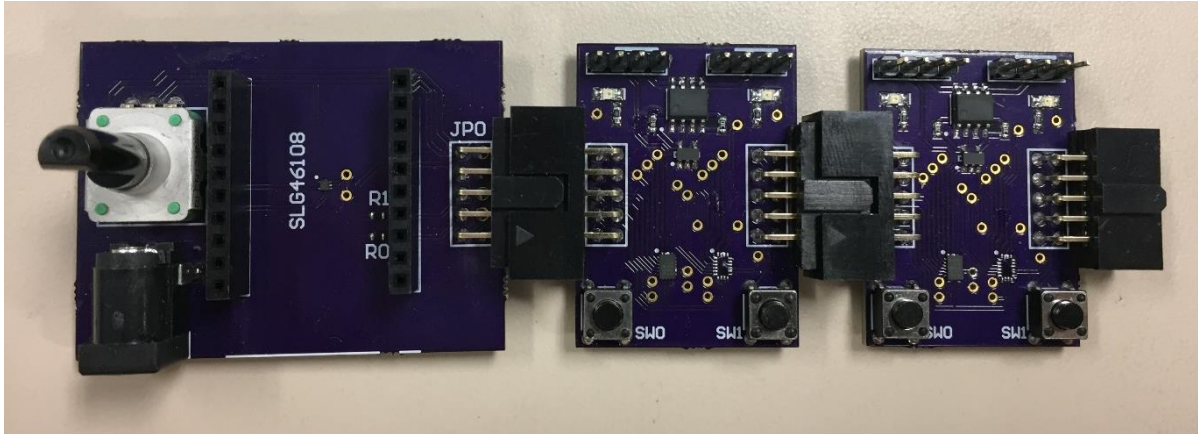

Figure 18. PCBs and Connectors

Each Fan Board has a shrouded male header on the left side and a female header on the right side so that they can be daisy-chained together. Each Fan Board can be populated with resources to independently control two fans.

8 C# Application

A C# application was written to interface with the Fan Boards through the FT232H USB-I²C bridge. This application can be used to adjust the frequency of each fan with I²C commands that are generated by the application.



Figure 19. C# Application GUI

The application pings all 16 I²C addresses once per second and populates the GUI with the slave addresses that are present. In this example Fan 1 (slave address 0001) and Fan 3 (slave address 0011) connected to the board. Adjustments to the duty cycle of each fan individually can be made by moving the slider bar or by typing a value from 0-256 in the textbox underneath the slider bar.

9 Conclusions

Using this design it is possible to independently control up to 16 fans (since there are 16 possible I²C slave addresses) either with a rotary encoder or with a C# application. It has been demonstrated how to generate a PWM signal with a pair of offset counters, and how to increase and decrease the duty cycle of that signal without rollover.

Revision History

Revision	Date	Description
1.0	03-Aug-2018	Initial Version

PWM Control for PC Fans

Status Definitions

Status	Definition
DRAFT	The content of this document is under review and subject to formal approval, which may result in modifications or additions.
APPROVED or unmarked	The content of this document has been approved for publication.

Disclaimer

Information in this document is believed to be accurate and reliable. However, Dialog Semiconductor does not give any representations or warranties, expressed or implied, as to the accuracy or completeness of such information. Dialog Semiconductor furthermore takes no responsibility whatsoever for the content in this document if provided by any information source outside of Dialog Semiconductor.

Dialog Semiconductor reserves the right to change without notice the information published in this document, including without limitation the specification and the design of the related semiconductor products, software and applications.

Applications, software, and semiconductor products described in this document are for illustrative purposes only. Dialog Semiconductor makes no representation or warranty that such applications, software and semiconductor products will be suitable for the specified use without further testing or modification. Unless otherwise agreed in writing, such testing or modification is the sole responsibility of the customer and Dialog Semiconductor excludes all liability in this respect.

Customer notes that nothing in this document may be construed as a license for customer to use the Dialog Semiconductor products, software and applications referred to in this document. Such license must be separately sought by customer with Dialog Semiconductor.

All use of Dialog Semiconductor products, software and applications referred to in this document are subject to Dialog Semiconductor's [Standard Terms and Conditions of Sale](http://www.dialog-semiconductor.com), available on the company website (www.dialog-semiconductor.com) unless otherwise stated.

Dialog and the Dialog logo are trademarks of Dialog Semiconductor plc or its subsidiaries. All other product or service names are the property of their respective owners.

© 2018 Dialog Semiconductor. All rights reserved.

Contacting Dialog Semiconductor

United Kingdom (Headquarters)

Dialog Semiconductor (UK) LTD
Phone: +44 1793 757700

Germany

Dialog Semiconductor GmbH
Phone: +49 7021 805-0

The Netherlands

Dialog Semiconductor B.V.
Phone: +31 73 640 8822

Email:

enquiry@diasemi.com

North America

Dialog Semiconductor Inc.
Phone: +1 408 845 8500

Japan

Dialog Semiconductor K. K.
Phone: +81 3 5769 5100

Taiwan

Dialog Semiconductor Taiwan
Phone: +886 281 786 222

Web site:

www.dialog-semiconductor.com

Hong Kong

Dialog Semiconductor Hong Kong
Phone: +852 2607 4271

Korea

Dialog Semiconductor Korea
Phone: +82 2 3469 8200

China (Shenzhen)

Dialog Semiconductor China
Phone: +86 755 2981 3669

China (Shanghai)

Dialog Semiconductor China
Phone: +86 21 5424 9058