

Application Note

A Boost Converter Design for Energy Harvesting Applications. Part 2

AN-CM-217

Abstract

Addendum to “A Boost Converter Design for Energy Harvesting Applications” explains the difference between Li-Ion charging and Lead-Acid charging.

This application note comes complete with design files which can be found in the References section.

A Boost Converter Design for Energy Harvesting Applications. Part 2**Contents**

Abstract	1
Contents	2
Figures	2
1 Terms and Definitions	3
2 References	3
3 A Boost Converter Design for Energy Harvesting Applications	4
Revision History	6

Figures

Figure 1: Schematic-Level Addition for Li-Ion Charging	4
Figure 2: GreenPAK Designer changes for Li-Ion charging	5

A Boost Converter Design for Energy Harvesting Applications. Part 2

1 Terms and Definitions

ACMP	Analog comparator module
GPIO	General-purpose input/output
Li-ion	Lithium-ion
NAND gate	Negative-AND, a logic gate which produces an output which is false only if all its inputs are true; thus its output is complement to that of the AND gate

2 References

For related documents and software, please visit:

<https://www.dialog-semiconductor.com/configurable-mixed-signal>.

Download our free **GreenPAK™** Designer software [1] to open the .gp files [1] and view the proposed circuit design. Use the **GreenPAK** development tools [3] to freeze the design into your own customized IC in a matter of minutes. Dialog Semiconductor provides a complete library of application notes [4] featuring design examples as well as explanations of features and blocks within the Dialog IC.

- [1] [GreenPAK Designer Software](#), Software Download and User Guide, Dialog Semiconductor
- [2] [AN-CM-217 A Boost Converter Design for Energy Harvesting Applications. Part 2.gp](#), [GreenPAK](#) Design File, Dialog Semiconductor
- [3] [GreenPAK Development Tools](#), [GreenPAK](#) Development Tools Webpage, Dialog Semiconductor
- [4] [GreenPAK Application Notes](#), [GreenPAK](#) Application Notes Webpage, Dialog Semiconductor
- [5] “BU-409: Charging Lithium-ion”, Battery University, 2017-05-09
- [6] “A Designer’s Guide to Lithium (Li-ion) Battery Charging”, Article Library of Digi-Key Electronics, 2016-09-01
- [7] AN-1202 A Boost Converter Design for Energy Harvesting Applications (Part1), Application Note, Dialog Semiconductor

A Boost Converter Design for Energy Harvesting Applications. Part 2

3 A Boost Converter Design for Energy Harvesting Applications

It is useful to compare Li-Ion charging with Lead-Acid charging. The traditional lead-acid battery charge cycle has Bulk (often but not necessarily Constant Current), Absorb (Constant Voltage) and Float (Constant Voltage) phases. It is important to complete the charge cycle by running it through all three phases. Li-Ion battery charging differs from lead-acid charging in the following aspects:

- a. There is no Float phase – charging current must drop to zero once Absorption is complete; completion of Absorption is signaled by the charge current dropping to below 0.1C
- b. If charging is stopped before Absorption is complete, the battery life does not worsen as with lead acid batteries; in fact cutting short the Absorption phase or eliminating it altogether actually improves the battery life [5]
- c. Deeply discharged Li-Ion batteries need a trickle charge of 0.1C to make them ready for the Bulk phase
- d. Slow charging simplifies matters. From [6]: “the quicker the charge, the lower the capacity when the battery switches to the relatively slow constant-voltage part of the charging regime. For example, charging at 0.7 C results in a capacity of 50 to 70 percent when 4.1 or 4.2 V is reached, whereas charging at less than 0.2 C can result in a full battery as soon as the voltage reaches 4.1 or 4.2 V.”

A general-purpose Li-Ion charger therefore needs a fair amount of logic to take care of these different battery states and properties. However, things become interesting in the specific context of energy harvesting. Application Note AN-1202 [7] presents a boost converter for energy harvesting applications. This Note features a battery that is used to support the system when harvested energy runs low. What if we wanted a rechargeable Li-Ion battery here? Since we are dealing with loads that are not power hungry, it is more important to have extended battery life rather than have a battery charged to exactly 100% of capacity. This allows us to exploit property (b) above.

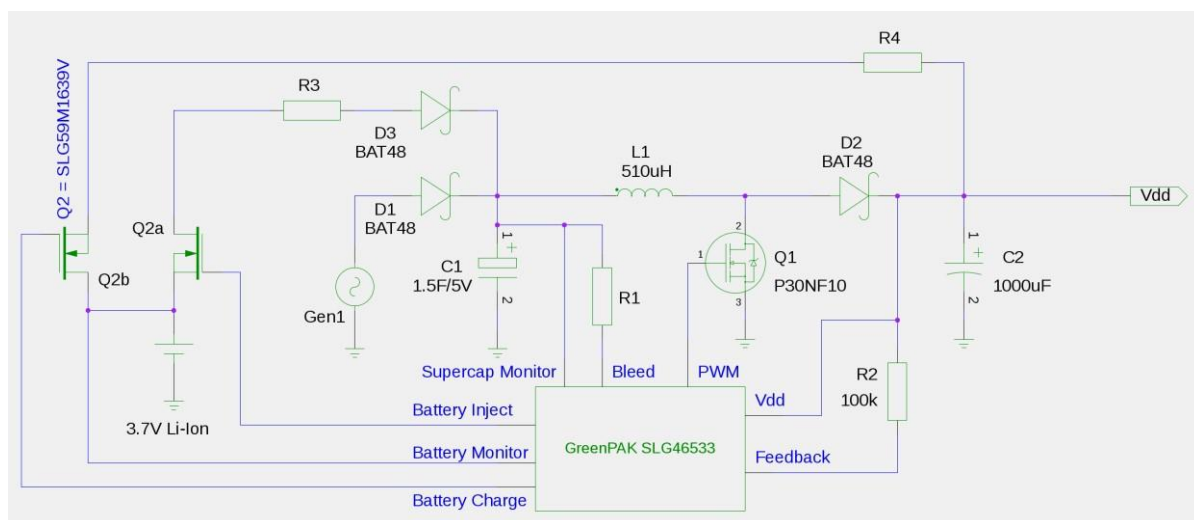

Figure 1: Schematic-Level Addition for Li-Ion Charging

Further, charging currents being low, we can also exploit property (d). These effectively imply that the Absorption phase offers no advantage and can be dispensed with. As long as we make a reasonable assumption that the Li-Ion battery will not be over-discharged (or design specifically for it), then (c) is also rendered largely irrelevant. Consequently, we are left with only the Bulk phase to contend with. Therefore, we can quite easily incorporate Li-Ion battery charging capability into the design presented in AN-1202 with the addition of a single resistor R4 and a GreenFET Q2b as shown in Figure 1, which will be controlled by the GreenPAK via the GPIO line marked Battery Charge. The additional piece conveniently operates off the 5V output!

(The single GreenFET in AN-1202 has been replaced by a dual GreenFET here.) When Q2b is on, the battery charges via the 5 V output of the system. The value of R4 must be chosen so that the overall load is small enough to not cause excessive output ripple; it should at any rate be no more than 0.1 C. Q2b is turned on via the Battery Charge GPIO pin only when the supercap is fully charged,

A Boost Converter Design for Energy Harvesting Applications. Part 2

and the battery is not fully charged. If the battery as well as supercap are fully charged, harvested energy is bled away as before through R1. The change in the bleed logic is implemented by modifying the associated GreenPAK Designer diagram as shown.

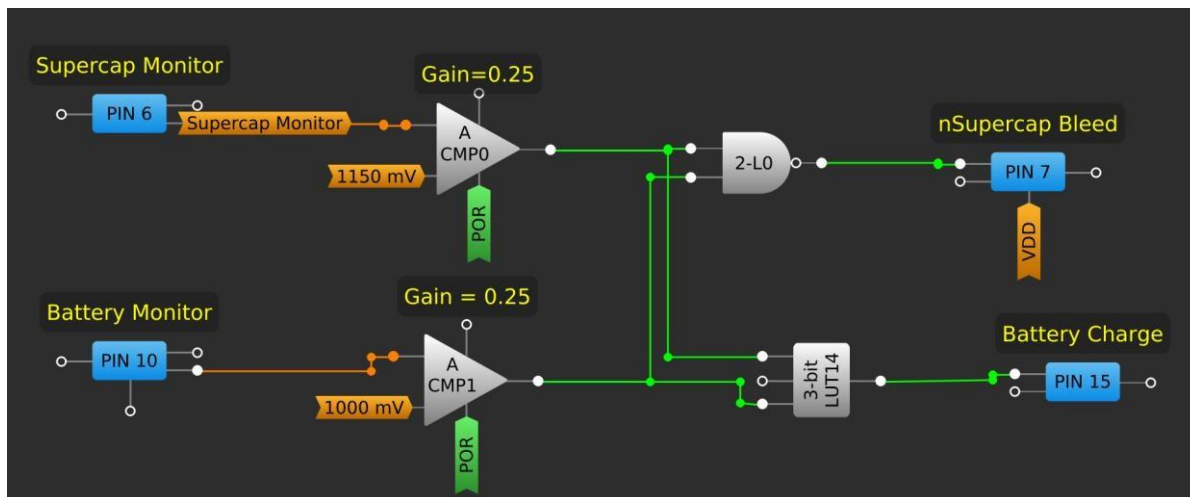

Figure 2: GreenPAK Designer changes for Li-Ion charging

We now need an additional ACMP to monitor the battery voltage. In [Figure 2](#) this is ACMP1 which is configured with a hysteresis of 200 mV so that when the battery voltage is above 4 V, it is deemed full enough and when it falls below 3.2 V it flags the need for charging. The supercap voltage is monitored by ACMP0. NAND gate L0 bleeds the supercap when the supercap and battery are both charged, whereas LUT14 outputs a high to turn on Q2b to charge the battery when the battery voltage is below 3.2 V and the supercap is fully charged.

(Note: In comparing [Figure 2](#) of AN-1202 and [Figure 2](#) in this Addendum, it will be evident that some ACMP labels have changed; this is because some ACMPs cannot be configured independently of others. For this reason, a few GPIO assignments are also different.)

A Boost Converter Design for Energy Harvesting Applications. Part 2**Revision History**

Revision	Date	Description
1.0	29-Nov-2107	Initial Version

A Boost Converter Design for Energy Harvesting Applications. Part 2

Status Definitions

Status	Definition
DRAFT	The content of this document is under review and subject to formal approval, which may result in modifications or additions.
APPROVED or unmarked	The content of this document has been approved for publication.

Disclaimer

Information in this document is believed to be accurate and reliable. However, Dialog Semiconductor does not give any representations or warranties, expressed or implied, as to the accuracy or completeness of such information. Dialog Semiconductor furthermore takes no responsibility whatsoever for the content in this document if provided by any information source outside of Dialog Semiconductor.

Dialog Semiconductor reserves the right to change without notice the information published in this document, including without limitation the specification and the design of the related semiconductor products, software and applications.

Applications, software, and semiconductor products described in this document are for illustrative purposes only. Dialog Semiconductor makes no representation or warranty that such applications, software and semiconductor products will be suitable for the specified use without further testing or modification. Unless otherwise agreed in writing, such testing or modification is the sole responsibility of the customer and Dialog Semiconductor excludes all liability in this respect.

Customer notes that nothing in this document may be construed as a license for customer to use the Dialog Semiconductor products, software and applications referred to in this document. Such license must be separately sought by customer with Dialog Semiconductor.

All use of Dialog Semiconductor products, software and applications referred to in this document are subject to Dialog Semiconductor's [Standard Terms and Conditions of Sale](http://www.dialog-semiconductor.com), available on the company website (www.dialog-semiconductor.com) unless otherwise stated.

Dialog and the Dialog logo are trademarks of Dialog Semiconductor plc or its subsidiaries. All other product or service names are the property of their respective owners.

© 2018 Dialog Semiconductor. All rights reserved.

Contacting Dialog Semiconductor

United Kingdom (Headquarters)

Dialog Semiconductor (UK) LTD
Phone: +44 1793 757700

Germany

Dialog Semiconductor GmbH
Phone: +49 7021 805-0

The Netherlands

Dialog Semiconductor B.V.
Phone: +31 73 640 8822

Email:

enquiry@diasemi.com

North America

Dialog Semiconductor Inc.
Phone: +1 408 845 8500

Japan

Dialog Semiconductor K. K.
Phone: +81 3 5769 5100

Taiwan

Dialog Semiconductor Taiwan
Phone: +886 281 786 222

Web site:

www.dialog-semiconductor.com

Hong Kong

Dialog Semiconductor Hong Kong
Phone: +852 2607 4271

Korea

Dialog Semiconductor Korea
Phone: +82 2 3469 8200

China (Shenzhen)

Dialog Semiconductor China
Phone: +86 755 2981 3669

China (Shanghai)

Dialog Semiconductor China
Phone: +86 21 5424 9058