

AN-1209 Constant Current RGB LED Driver

This application note describes how to create a constant current RGB LED driver using the SLG46580V. By enabling and disabling the GreenPAK™'s internal power switches, the designer can regulate the current flow through the individual LEDs of an RGB LED. This system is based on ACMP feedback that measures the voltage across current limiting resistors for each of the LEDs. The constant current levels can be adjusted through I2C for each LED.

Basic Idea and Circuit Layout

Figure 1 shows the circuit schematic for this design. The current regulation is achieved by monitoring R1, R2, and R3 with analog comparators (ACMPs) to enable and disable the GreenPAK's internal power switches.

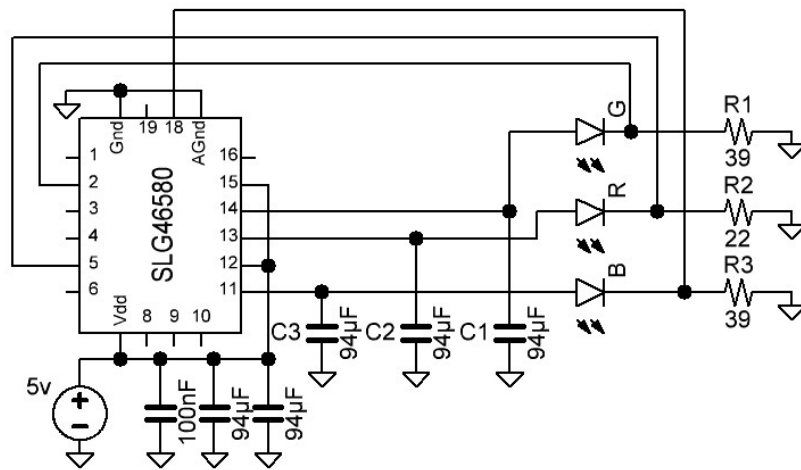

Figure 1. Constant Current RGB Driver Circuit Schematic

When enabled, these switches charge up the output capacitors which increases the voltage across them. Assuming the forward voltage drop of the LEDs stays constant, increasing the output capacitor voltage will increase the voltage across the resistor and, as a result, will increase the current through the LED.

When disabled, the charge stored on the output capacitors will be used to source the current through the LEDs. As current is drawn from the capacitors (C1, C2, and C3), their voltages will begin to drop and the current through the LEDs will decrease. When the voltage across the current limiting resistors falls below the acceptable threshold, the power switches are re-enabled.

The enabling and disabling of the power switches makes up the feedback loop of this regulatory system. Since the power switch is periodically turning on and off, there will be a ripple voltage present across the resistors as shown in Figure 2. The magnitude and frequency of this ripple voltage depends on the strength of the input voltage source, the current drawn by the LED, the capacitive load size, and the internal delays of the GreenPAK design.

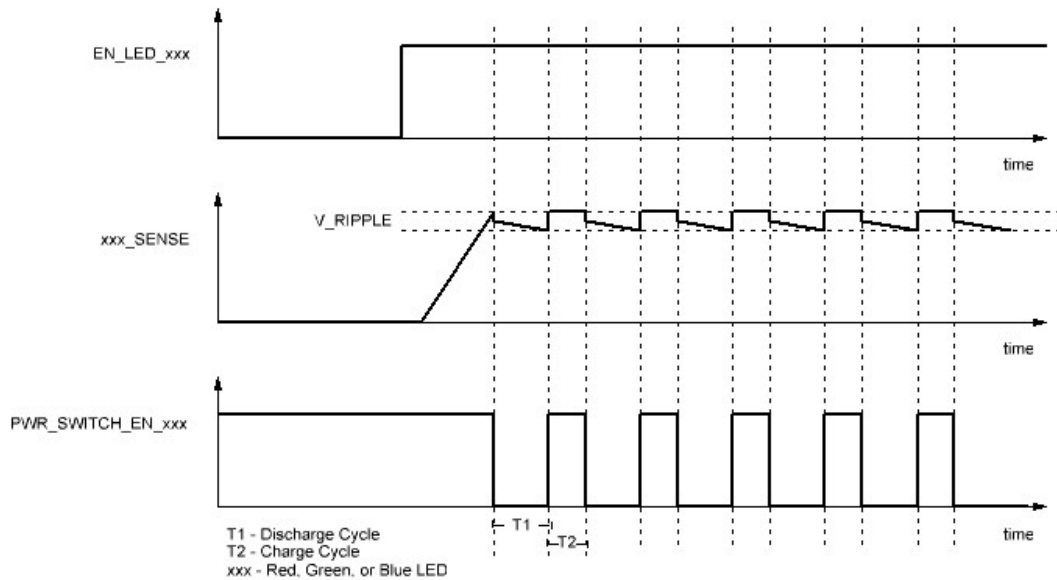

Figure 2. Constant Current Functional Waveform

By changing the ACMP's IN- reference voltage, the constant current level can be changed. Table 1 shows the register values and respective current levels associated with each of the internal reference voltages.

Register Value	ACMP V_{REF} (mV)	$I_{BLUE/GREEN}$ (mA)	I_{RED} (mA)
0x00	50	1.3	2.3
0x01	100	2.6	4.5
0x02	150	3.8	6.8
0x03	200	5.1	9.1
0x04	250	6.4	11.4
0x05	300	7.7	13.6
0x06	350	9.0	15.9
0x07	400	10.2	18.2
0x08	450	11.5	20.4
0x09	500	12.8	22.7
0x0A	550	14.1	25.0
0x0B	600	15.4	27.3
0x0C	650	16.7	29.5
0x0D	700	17.9	31.8
0x0E	750	19.2	34.1
0x0F	800	20.6	36.4
0x10	850	21.8	38.6
0x11	900	23.1	40.9
0x12	950	24.3	43.2
0x13	1000	25.6	45.4
0x14	1050	26.9	47.7
0x15	1100	28.2	50.0
0x16	1150	29.5	52.3
0x17	1200	30.8	54.5

Table 1. ACMP V_{REF} Relation to LED Current

GreenPAK Design

Figure 3 shows the SLG46580V GreenPAK design for this constant current RGB Driver. This figure shows the ACMP SENSE pins on the left-hand side which monitor the voltages across the current limiting resistors. When the SENSE pin voltages drop below the internal threshold voltages, the power switches close. As the output capacitors are connected to 5V, the capacitor voltages increase quickly and cause a voltage jump on the SENSE pins. This voltage jump results in higher current flow through the LEDs. The delay blocks force the power switches to be disabled for an additional 1 μ s before allowing the power switches to turn on. This helps create a more accurate average current by accommodating for the increased current when the power switch is enabled. The 3-bit LUTs act as inverters when either their GPIO or I2C enables are set high; otherwise, these LUTs disable the power switches.

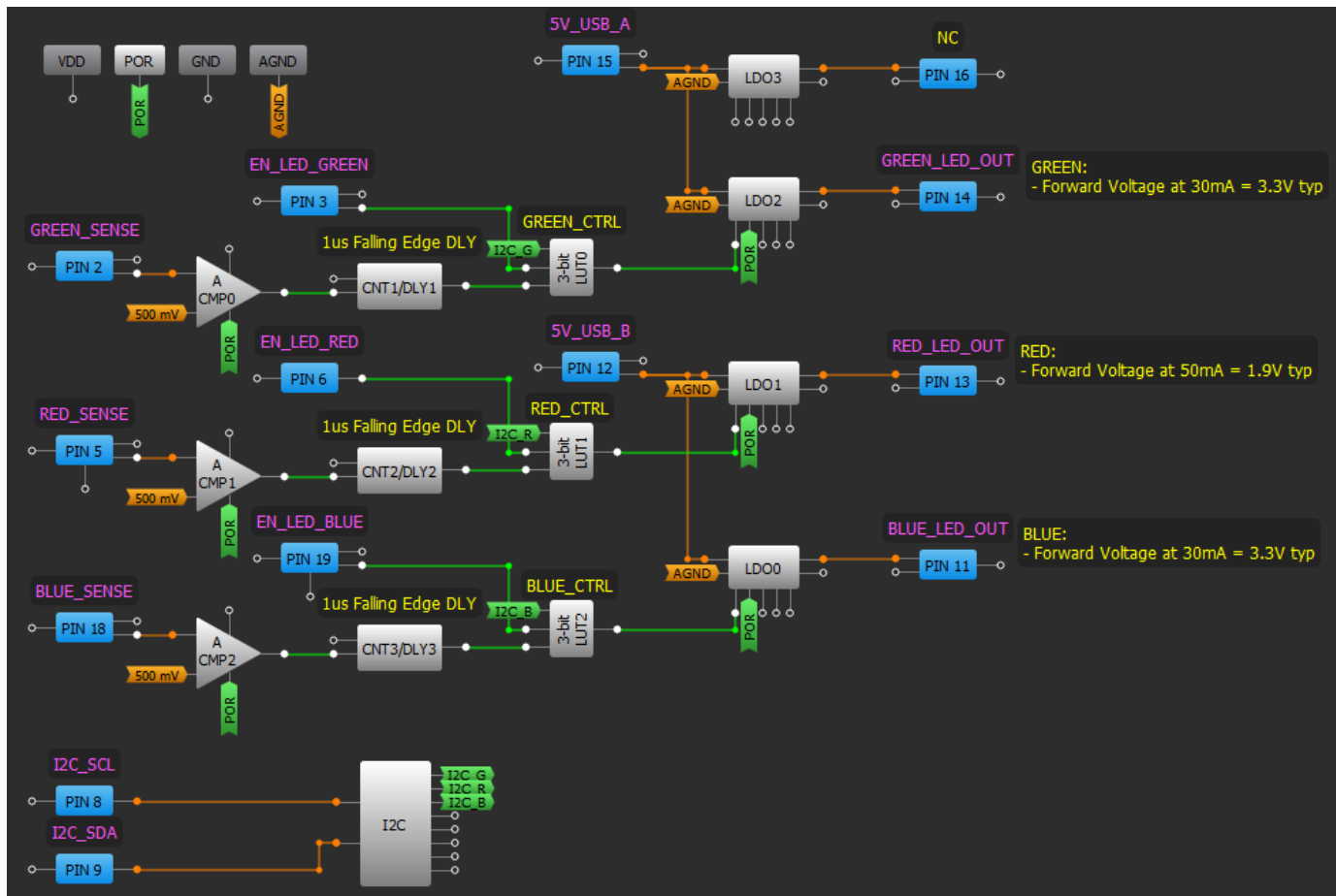

Figure 3. GreenPAK Constant Current RGB Driver Design

I2C Features

By using I2C, the user can alter the ACMP IN- reference voltages to change the constant current settings. In addition, the LEDs can be enabled using the I2C virtual pin inputs. Table 2 shows the register locations of these features.

	ACMP0	ACMP1	ACMP2	ACMP3	I2C Virtual Input
Register	Reg<1628:1624>	Reg<1636:1632>	Reg<1644:1640>	Reg<1652:1648>	Reg<1959:1952>

Table 2. I2C Registers

For more I2C information, please check out AN-1090 (Simple I2C IO Controllers with SLG46531V) and AN-1091 (How to change a GreenPAK comparator's threshold voltage using I2C) on Silego's website. Please reference the SLG46580V datasheet for more register information.

Component Selection

RGB LED Selection:

I've selected a Kingbright RGB LED. (PN: AAAF5060QBFSURZGS) It is important to note that this LED isn't a common anode or a common cathode LED, but rather, it contains 3 individual red,

green, and blue LEDs. Table 3 lists some of the important specifications for this LED.

	Blue	Red	Green	Units
Material	InGaN	AlGaInP	InGaN	--
DC Forward Current	30	50	30	mA
Peak Forward Current	150	185	150	mA
Forward Voltage (typ, max)*	3.3, 4	1.9, 2.5	3.3, 4.1	V
Dominant Wavelength*	465	630	525	nm
Luminous Intensity (min, typ)**	280, 400	500, 800	500, 1000	mcd

Table 3. Kingbright RGB LED Specifications

Notes:

* - $I_F = 20mA$

** - $I_F = 30mA$ for Blue and Green, $50mA$ for Red

Since the average DC forward current of the Kingbright LED is 30 and 50 mA, we are well within the SLG46580V's 150mA power switch limitation. For this design, we are planning to run off a 5V supply. Given the typical 3.3V forward voltage of these LEDs, we have sufficient headroom for use in our ACMP feedback system as will be described in the current limiting resistor section.

Current Limiting Resistor Selection: (R1, R2, R3)

When selecting the resistors for the RGB LEDs, we must perform a couple simple calculations to estimate the proper size. First, we need to know that the maximum reference voltage of the SLG46580V's ACMP is 1.2V. Since the IN- reference voltages of the ACMPs are in 50mV increments, we want to select the largest resistor value to obtain the best current resolution whilst staying under the 1.2V limitation of the ACMP and the 5V power supply limit.

Equation 1 calculates the maximum current limiting resistor voltage to be 1.7V. Since the ACMP input reference is limited to a maximum of 1.2V without an input resistive divider, we should aim to have 1.2V across the current limiting resistors at the maximum current draw.

$$V_{CLRes} \leq V_{SUP} - V_{Forward} = 5V - 3.3V = 1.7V$$

$$\therefore V_{CLRes} = 1.2V$$

Equation 1. Maximum Current Limiting Resistor Voltage Calculation

Once we've selected the maximum current limiting resistor voltage, we can use Equation 2 to select the appropriate resistor value for both the 30mA and 50mA cases. Since 40Ω and 24Ω are not standard resistor values, we will select 39Ω and 22Ω respectively as shown in Figure 1.

$$R \leq \frac{V_{CLRes}}{I_{30}} = \frac{1.2V}{30mA} = 40\Omega \text{ (For Green and Blue LEDs)}$$

$$R \leq \frac{V_{CLRes}}{I_{50}} = \frac{1.2V}{50mA} = 24\Omega \text{ (For Red LEDs)}$$

Equation 2. Current Limiting Resistor Calculation

We could increase the range from 1.2V to 1.7V if we use a resistive divider on the ACMP inputs, but we would decrease the current resolution of the ACMP. For example, if we used an input divide by 2, the voltage change across the resistors would be in 100mV steps instead of 50mV steps. We would get 17 steps using the 1.7V limit with the input divide by 2, but we get 24 steps if we use 1.2V without an input divider.

Power Switch Output Capacitor Selection: (C1, C2, C3)

The output capacitor selection impacts a couple factors including the average current accuracy and the initial turn on time of the LEDs. If the power switch is closed, the input sources current to charge the output capacitor. As the output voltage exceeds the ACMP IN- reference, the power switch turns off and the output capacitor begins to source the charge for the LED until the output

voltage drops below the ACMP's IN- reference. This charge cycle creates an output ripple voltage across the current limiting resistor that translates directly into current ripple.

Over time, this current ripple can be averaged to determine the brightness of the LED. The size of the capacitor impacts the accuracy of the averaged current.

For larger capacitors, the charge and discharge cycles in Figure 2 take longer. As a result, the ripple voltage is minimized and the average current matches closely with the ideal current calculations. With the increase in output capacitance, the initial turn on time of the LED is increased.

The capacitor's charge is much more fluid for smaller capacitors in that they charge and discharge more quickly. This results in voltage ripples that are larger than those measured with bigger capacitors. The average current differs significantly at low current levels because the charge and discharge cycles can be fast compared to the minimum 1µs delay times of the GreenPAK's DLY blocks. For smaller capacitors, the initial turn on time is quicker than that of larger capacitors.

Experimental Results

I tested this constant current LED driver design with four capacitive loads: 1µF, 10µF, 47µF, and 94µF. The next couple paragraphs will address the results with the Green LED inside the RGB LED package. The Red and Blue LEDs produced similar results, so I've skipped their waveforms for brevity's sake. Please see Appendix A for the raw data. I've also included the raw data using a 47µF input capacitor instead of a 94µF capacitor.

Figure 4 plots the constant current drive level through the green LED vs the ACMP reference voltages for various capacitive loads. The deviation from the calculated current level is caused by the voltage jump across the current sense resistor as the power switch is enabled. This design tries to counteract this behavior by keeping the power switch disabled for an additional 1µs.

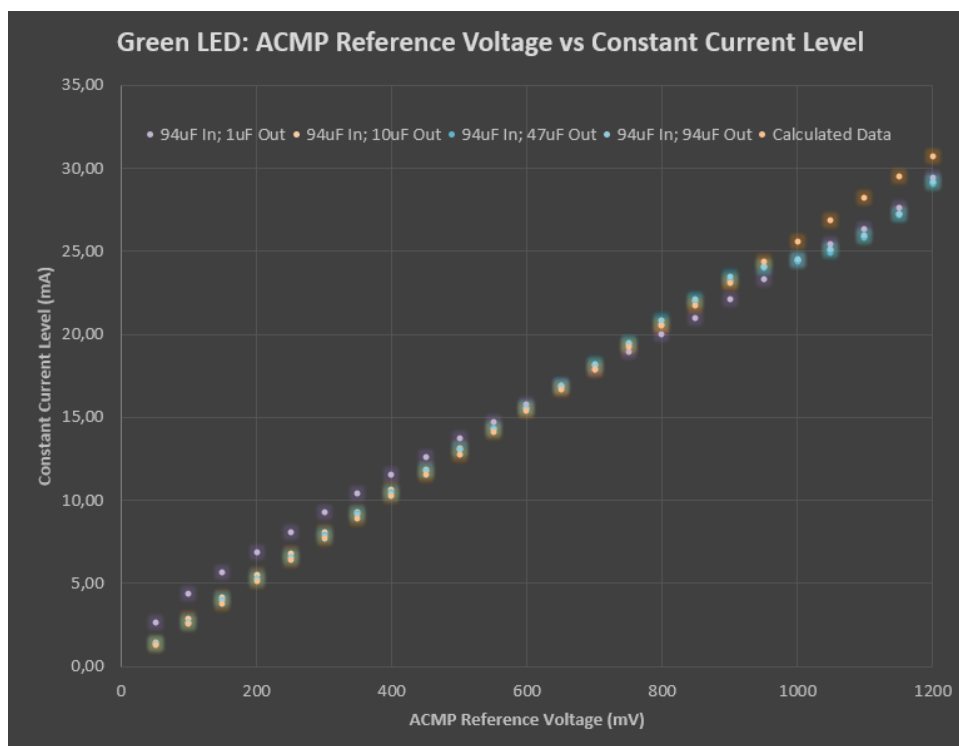

Figure 4. ACMP Reference Voltage vs Constant Current Level for Various Capacitive Loads (Green LED)

The percent error of the drive current can be used to see how far off the measured current levels are from the theoretical current levels. Equation 3 shows the calculation used to obtain the data in Figure 5.

$$Percent\ Error_{Current} = \frac{I_{Meas} - I_{True}}{I_{True}} * 100$$

Equation 3. Percent Error Equation

By looking at Figure 5, we can see that the 94µF capacitor performs more accurately than the other capacitive loads. Due to excessive charging at low current levels, the 1µF capacitor reaches 100%

error. This may not be problematic for an application if the desired current levels do not need to be precise.

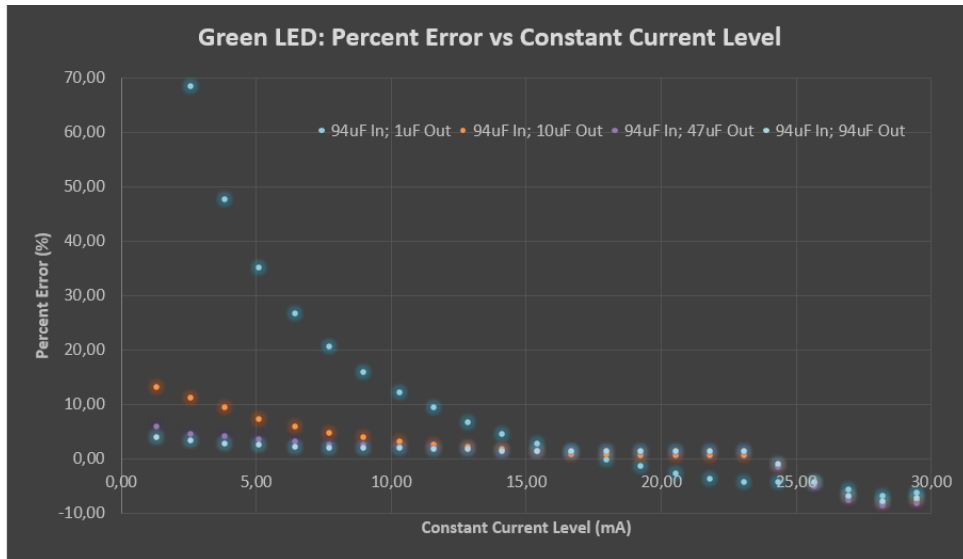

Figure 5. Percent Error vs Constant Current Level for Various Capacitive Loads (Green LED)

On the surface, selecting large output capacitors appears to be the best solution, but by selecting a large capacitance, the inrush current and the turn on time of the LEDs increase. The designer needs to pay attention to this inrush current as it can cause the input voltage rail to droop. The input voltage droop can be minimized by having a larger capacitor to pull charge from when the power switch is initially enabled. Note that the strength of your drive source will also impact the amount of input voltage droop. Weaker sources will experience more voltage droop than stronger sources.

For this design, there are two startup times to consider: partially and fully discharged. When the LED is disabled for a long time (10-20 seconds), the output capacitors discharge significantly by leaking through the LED. Fully discharged capacitors can take 10 μ s to 150 μ s to charge up before being able to supply 30mA of current as shown in Figure 6.

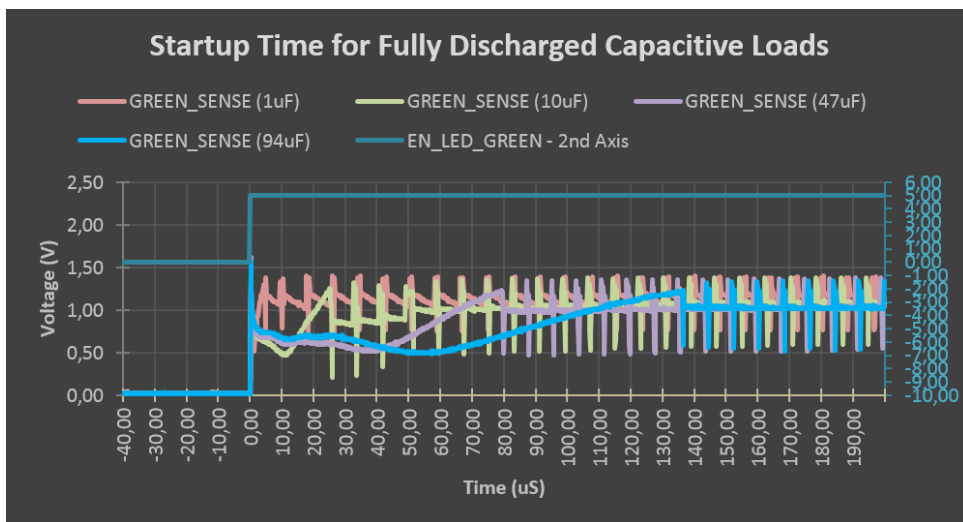

Figure 6. Startup Time for Fully Discharged Capacitive Loads (94 μ F Input Capacitors)

If the LEDs are being cycled at a quicker rate, the initial turn on times decrease for each of the capacitive loads. For partially discharged capacitive loads, the turn on time can range from 5 μ s to 50 μ s as seen in Figure 7.

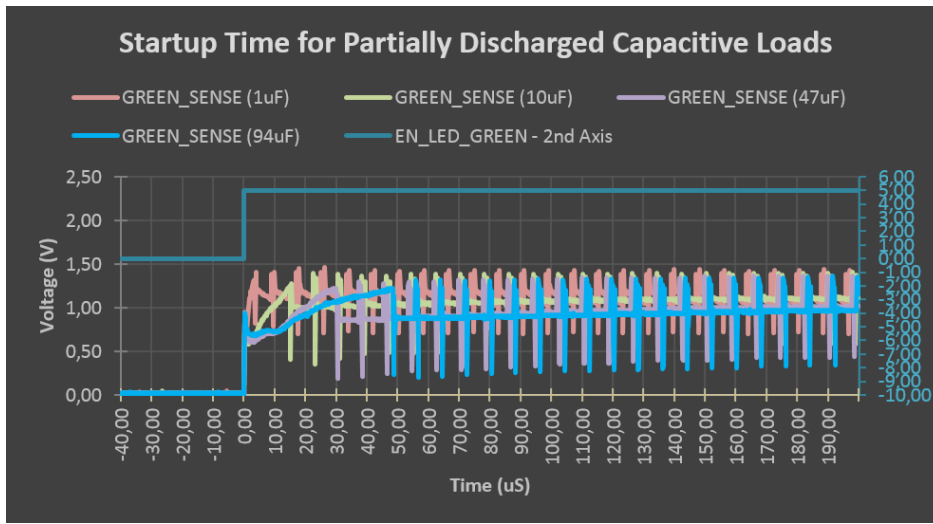

Figure 7. Startup Time for Partially Discharged Capacitive Loads (94 μ F Input Capacitors)

Figure 8 shows the steady-state, periodic behavior of this design for various loads. This figure shows the previously described voltage jump when the LDO is enabled or disabled and should match the functional waveform shown in Figure 2.

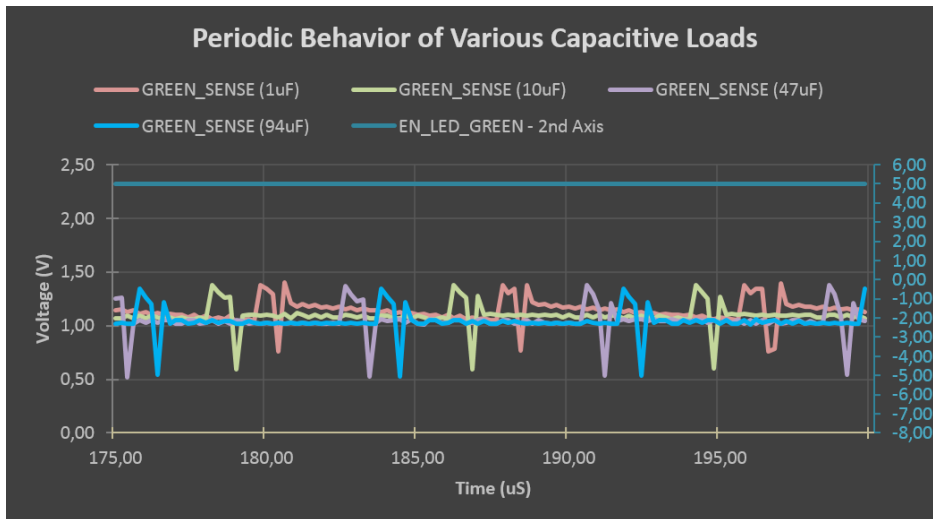

Figure 8. Periodic Behavior of the Various Capacitive Loads (94 μ F Input Capacitors)

The waveforms above show the performance of this design for applications with varying capacitive loads. The capacitive load size selection depends entirely on the application. For this application note, these results show that the startup time for the LED is about 140 μ s for a 94 μ F load capacitor. In addition, the actual current will not deviate more than $\pm 5\%$ from the calculated current levels.

Going Further

This design demonstrates the process of creating a constant current LED driver using the SLG46580V. If one wanted to expound upon this idea, the designer could use an I2C script to create various patterns and colors for the RGB LED.

This design could also be used with an external DAC to provide more reference voltage steps for the ACMP. This would create finer current control for the RGB LEDs.

This design can support constant current designs for LEDs with DC forward currents greater than the 30mA and 50mA examples used in this application note. Table 4 shows the available GreenPAK devices with the corresponding power switch quantity and maximum current limitation.

GreenPAK	# of Power Switches	I _{MAX} Limitation per Switch
SLG46580V	4	150mA
SLG46582V	2	300mA
SLG46583V	1	600mA

Table 4. Power Switch Availability

Conclusion

This constant current driver can be used in conjunction with a microcontroller to source current for LEDs in many different applications. By regulating the current flow through an external current limiting resistor, the designer can control the brightness of each of the LEDs in his or her circuit. The component selection process outlined in this application note will help create a constant current LED driver with the maximum number of current steps using the GreenPAK's internal reference voltages. By extending these principles, this design can become the foundation for creating a simple constant current LED driver for many applications.

Appendix A: Raw Measurement Data

1 μ F		Green			Red			Blue					
		Meas	Calc	% Error	Meas	Calc	% Error	Meas	Calc	% Error			
0x00	50	0.10379247	2.66	1.28	107.58	0.11537794	5.24	2.27	130.76	0.12175323	3.12	1.28	143.51
0x01	100	0.16615782	4.26	2.56	66.16	0.17511562	7.96	4.55	75.12	0.1817855	4.66	2.56	81.79
0x02	150	0.21896942	5.61	3.85	45.98	0.22550583	10.25	6.82	50.34	0.23340979	5.98	3.85	55.61
0x03	200	0.26772105	6.86	5.13	33.86	0.2725134	12.39	9.09	36.26	0.28182527	7.23	5.13	40.91
0x04	250	0.3138484	8.05	6.41	25.54	0.31727374	14.42	11.36	26.91	0.32801675	8.41	6.41	31.21
0x05	300	0.35858112	9.19	7.69	19.53	0.36042987	16.38	13.64	20.14	0.37283955	9.56	7.69	24.28
0x06	350	0.40275658	10.33	8.97	15.07	0.40293702	18.32	15.91	15.12	0.4173867	10.70	8.97	19.25
0x07	400	0.44640148	11.45	10.26	11.60	0.44465317	20.21	18.18	11.16	0.46106654	11.82	10.26	15.27
0x08	450	0.48936079	12.55	11.54	8.75	0.48620648	22.10	20.45	8.05	0.50447927	12.94	11.54	12.11
0x09	500	0.53081713	13.61	12.82	6.16	0.52495704	23.86	22.73	4.99	0.54678054	14.02	12.82	9.36
0x0A	550	0.57271651	14.69	14.10	4.13	0.56565032	25.71	25.00	2.85	0.58792907	15.08	14.10	6.90
0x0B	600	0.61412511	15.75	15.38	2.35	0.60513991	27.51	27.27	0.86	0.6312687	16.19	15.38	5.21
0x0C	650	0.65496818	16.79	16.67	0.76	0.64342316	29.25	29.55	-1.01	0.67258659	17.25	16.67	3.47
0x0D	700	0.69520097	17.83	17.95	-0.69	0.68253692	31.02	31.82	-2.49	0.71408606	18.31	17.95	2.01
0x0E	750	0.7373418	18.91	19.23	-1.69	0.72365938	32.89	34.09	-3.51	0.75455878	19.35	19.23	0.61
0x0F	800	0.77610465	19.90	20.51	-2.99	0.76254207	34.66	36.36	-4.68	0.79664259	20.43	20.51	-0.42
0x10	850	0.81736643	20.96	21.79	-3.84	0.79704787	36.23	38.64	-6.23	0.83789071	21.48	21.79	-1.42
0x11	900	0.85988201	22.05	23.08	-4.46	0.85224812	38.74	40.91	-5.31	0.87721843	22.49	23.08	-2.53
0x12	950	0.90766286	23.27	24.36	-4.46	0.89109791	40.50	43.18	-8.20	0.91915932	23.57	24.36	-3.25
0x13	1000	0.95431436	24.47	25.84	-4.57	0.93842265	42.66	45.45	-6.16	0.96359729	24.71	25.64	-3.64
0x14	1050	0.97544291	25.01	26.92	-7.10	0.9848529	44.77	47.73	-8.20	1.00784423	25.84	26.92	-4.01
0x15	1100	1.00983025	25.89	28.21	-8.20	1.02724296	46.69	50.00	-6.61	1.05466384	27.04	28.21	-4.12
0x16	1150	1.06286018	27.25	29.49	-7.58	1.06923613	48.60	52.27	-7.02	1.10590202	28.36	29.49	-3.83
0x17	1200	1.13698422	29.15	30.77	-5.25	1.15238756	52.38	54.55	-3.97	1.15924573	29.72	30.77	-3.40

Table 5. Raw Data for 47 μ F Input / 1 μ F Output Capacitor

1 μ F		Green			Red			Blue					
		Meas	Calc	% Error	Meas	Calc	% Error	Meas	Calc	% Error			
0x00	50	0.10544961	2.70	1.28	110.90	0.11658766	5.30	2.27	133.18	0.1219656	3.13	1.28	143.93
0x01	100	0.16841484	4.32	2.56	68.41	0.17639123	8.02	4.55	76.39	0.18184723	4.66	2.56	81.85
0x02	150	0.22148852	5.68	3.85	47.66	0.22719944	10.33	6.82	51.47	0.23398508	6.00	3.85	55.99
0x03	200	0.2702408	6.93	5.13	35.12	0.27413039	12.46	9.09	37.07	0.28203652	7.23	5.13	41.02
0x04	250	0.31681257	8.12	6.41	26.73	0.31912763	14.51	11.36	27.65	0.32829134	8.42	6.41	31.32
0x05	300	0.36179645	9.28	7.69	20.60	0.36242803	16.47	13.64	20.81	0.37359763	9.58	7.69	24.53
0x06	350	0.40594958	10.41	8.97	15.99	0.40480821	18.40	15.91	15.66	0.41828879	10.73	8.97	19.51
0x07	400	0.44921564	11.52	10.26	12.30	0.44608536	20.28	18.18	11.52	0.46164798	11.84	10.26	15.41
0x08	450	0.49196858	12.61	11.54	9.33	0.49733012	22.15	20.45	8.30	0.50514277	12.95	11.54	12.25
0x09	500	0.53404017	13.69	12.82	6.81	0.52701476	23.96	22.73	5.40	0.54771031	14.04	12.82	9.54
0x0A	550	0.57548674	14.76	14.10	4.63	0.60427355	27.47	25.00	9.87	0.58997701	15.13	14.10	7.27
0x0B	600	0.61666606	15.81	15.38	2.78	0.60719107	27.60	27.27	1.20	0.63178835	16.20	15.38	5.30
0x0C	650	0.65797972	16.87	16.67	1.23	0.64528342	29.33	29.55	-0.73	0.67298954	17.26	16.67	3.54
0x0D	700	0.69866542	17.91	17.95	-0.19	0.6833907	31.06	31.82	-2.37	0.71545727	18.35	17.95	2.21
0x0E	750	0.7402992	18.98	19.23	-1.29	0.72499195	32.95	34.09	-3.33	0.75650091	19.40	19.23	0.87
0x0F	800	0.77923443	19.98	20.51	-2.60	0.76366601	34.71	36.36	-4.54	0.79802829	20.46	20.51	-0.25
0x10	850	0.819662	21.02	21.79	-3.57	0.79876461	36.31	38.64	-6.03	0.83916501	21.52	21.79	-1.27
0x11	900	0.86193967	22.10	23.08	-4.23	0.85408488	38.82	40.91	-5.10	0.87845455	22.52	23.08	-2.39
0x12	950	0.9106347	23.35	24.36	-4.14	0.88793466	40.36	43.18	-6.53	0.92064209	23.61	24.36	-3.09
0x13	1000	0.95426373	24.47	25.64	-4.57	0.93464328	42.48	45.45	-6.54	0.96424275	24.72	25.64	-3.58
0x14	1050	0.99187168	25.43	26.92	-5.54	0.98019999	44.55	47.73	-6.65	1.00857849	25.86	26.92	-3.94
0x15	1100	1.02673933	26.33	28.21	-6.66	1.02636925	46.65	50.00	-6.69	1.05540592	27.06	28.21	-4.05
0x16	1150	1.07916886	27.67	29.49	-6.16	1.07175653	48.72	52.27	-6.80	1.10651142	28.37	29.49	-3.78
0x17	1200	1.14910569	29.46	30.77	-4.24	1.15607567	52.55	54.55	-3.66	1.18008577	29.75	30.77	-3.33

Table 6. Raw Data for 94 μ F Input / 1 μ F Output Capacitor

10 μ F		Green			Red			Blue					
		Meas	Calc	% Error	Meas	Calc	% Error	Meas	Calc	% Error			
0x00	50	0.06696687	1.46	1.28	13.93	0.0608695	2.77	2.27	21.74	0.06364242	1.63	1.28	27.28
0x01	100	0.11190378	2.87	2.56	11.90	0.1167021	5.30	4.55	16.70	0.11729143	3.01	2.56	17.29
0x02	150	0.16386559	4.20	3.85	9.24	0.16933401	7.70	6.82	12.89	0.16829089	4.32	3.85	12.19
0x03	200	0.21452406	5.50	5.13	7.26	0.22096825	10.04	9.09	10.48	0.21900129	5.62	5.13	9.50
0x04	250	0.26469255	6.79	6.41	5.88	0.27264091	12.39	11.36	9.06	0.26849579	6.88	6.41	7.40
0x05	300	0.31427045	8.06	7.69	4.76	0.32385321	14.72	13.64	7.95	0.31903935	8.18	7.69	6.35
0x06	350	0.36356466	9.32	8.97	3.88	0.37505051	17.05	15.91	7.16	0.36874841	9.46	8.97	5.36
0x07	400	0.41306167	10.59	10.26	3.27	0.42597334	19.36	18.18	6.49	0.41871936	10.74	10.26	4.68
0x08	450	0.46215197	11.85	11.54	2.70	0.47648217	21.66	20.45	5.88	0.46798635	12.00	11.54	4.00
0x09	500	0.51098743	13.10	12.82	2.20	0.53380787	24.26	22.73	6.76	0.51768896	13.27	12.82	3.54
0x0A	550	0.55960819	14.35	14.10	1.75	0.58261136	26.48	25.00	5.93	0.56683641	14.53	14.10	3.06
0x0B	600	0.60814478	15.59	15.38	1.36	0.62860522	28.57	27.27	4.77	0.61631691	15.80	15.38	2.72
0x0C	650	0.65656522	16.84	16.67	1.01	0.68043583	30.93	29.55	4.68	0.66513055	17.05	16.67	2.33
0x0D	700	0.7053916	18.09	17.95	0.77	0.73217776	33.28	31.82	4.60	0.71416908	18.31	17.95	2.02
0x0E	750	0.75526266	19.37	19.23	0.70	0.78485439	35.68	34.09	4.65	0.76372485	19.58	19.23	1.83
0x0F	800	0.80548788	20.65	20.51	0.69	0.83361132	37.99	36.36	4.20	0.81248002	20.83	20.51	1.56
0x10	850	0.85543585	21.93	21.79	0.64	0.88269354	40.12	38.64	3.85	0.86449548	22.17	21.79	1.71
0x11	900	0.90548148	23.22	23.08	0.61	0.89966919	40.89	40.91	-0.04	0.91472816	23.45	23.08	1.64
0x12	950	0.92975533	23.84	24.36	-2.13	0.91862285	41.76	43.18	-3.30	0.96463776	24.73	24.36	1.54
0x13	1000	0.94440475	24.22	25.64	-5.56	0.94529897	42.97	45.45	-5.47	1.01494303	26.02	25.64	1.49
0x14	1050	0.9652224	24.75	26.92	-8.07	0.98863585	44.94	47.73	-5.84	1.06544166	27.32	26.92	1.47
0x15	1100	0.99919215	25.62	28.21	-9.16	1.05643345	48.02	50.00	-3.96	1.11603657	28.62	28.21	1.46
0x16	1150	1.0515009	26.96	29.49	-8.57	1.15793781	52.63	52.27	0.69	1.16646977	29.91	29.49	1.43
0x17	1200	1.12696417	28.90	30.77	-6.09	1.25019887	56.83	54.55	4.18	1.21734881	31.21	30.77	1.45

Table 7. Raw Data for 47 μ F Input / 10 μ F Output Capacitor

10 μ F		Green			Red			Blue					
		Meas	Calc	% Error	Meas	Calc	% Error	Meas	Calc	% Error			
0x00	50	0.05667659	1.45	1.28	13.35	0.08039193	2.75	2.27	20.78	0.0831777	1.62	1.28	26.38
0x01	100	0.1114737	2.86	2.56	11.47	0.11675404	5.31	4.55	16.75	0.11677163	2.99	2.56	16.77
0x02	150	0.16397112	4.20	3.85	9.31	0.16956418	7.71	6.82	13.04	0.16766698	4.30	3.85	11.78
0x03	200	0.21453805	5.50	5.13	7.27	0.22109595	10.05	9.09	10.55	0.21866362	5.61	5.13	9.33
0x04	250	0.26449718	6.78	6.41	5.80	0.27298962	12.41	11.36	9.20	0.2687388	6.89	6.41	7.50
0x05	300	0.31443897	8.06	7.69	4.81	0.3239341	14.72	13.64	7.98	0.31862643	8.17	7.69	6.21
0x06	350	0.36373456	9.33	8.97	3.92	0.37484507	17.04	15.91	7.10	0.36824002	9.44	8.97	5.21
0x07	400	0.41308802	10.59	10.26	3.27	0.4258419	19.36	18.18	6.46	0.41829517	10.73	10.26	4.57
0x08	450	0.46216109	11.85	11.54	2.70	0.47643272	21.66	20.45	5.87	0.46777219	11.99	11.54	3.95
0x09	500	0.51139805	13.11	12.82	2.28	0.53307068	24.23	22.73	6.61	0.51733506	13.27	12.82	3.47
0x0A	550	0.56013487	14.36	14.10	1.84	0.58359091	26.53	25.00	6.11	0.56672071	14.53	14.10	3.04
0x0B	600	0.60853462	15.60	15.38	1.42	0.62771951	28.53	27.27	4.62	0.61568856	15.79	15.38	2.61
0x0C	650	0.65709471	16.85	16.67	1.09	0.68043057	30.93	29.55	4.68	0.66477022	17.05	16.67	2.27
0x0D	700	0.70591019	18.10	17.95	0.84	0.73302461	33.32	31.82	4.72	0.71382589	18.30	17.95	1.98
0x0E	750	0.75570922	19.38	19.23	0.76	0.78416394	35.64	34.09	4.56	0.76305229	19.57	19.23	1.74
0x0F	800	0.80650331	20.68	20.51	0.81	0.83453021	37.93	36.36	4.32	0.81203826	20.82	20.51	1.50
0x10	850	0.85541153	21.93	21.79	0.64	0.88538484	40.24	38.64	4.16	0.86357862	22.14	21.79	1.60
0x11	900	0.90564218	23.22	23.08	0.63	0.9121895	41.46	40.91	1.35	0.91405471	23.44	23.08	1.56
0x12	950	0.93859806	24.07	24.36	-1.20	0.93358964	42.44	43.18	-1.73	0.96344014	24.70	24.36	1.41
0x13	1000	0.95464993	24.48	25.64	-4.54	0.96179225	43.72	45.45	-3.82	1.01358792	25.99	25.64	1.36
0x14	1050	0.97648599	25.04	26.92	-7.00	1.00526445	45.69	47.73	-4.26	1.06392257	27.28	26.92	1.33
0x15	1100	1.01062508	25.91	28.21	-8.12	1.07413981	48.82	50.00	-2.35	1.11461595	28.58	28.21	1.33
0x16	1150	1.06282538	27.25	29.49	-7.58	1.17652837	53.48	52.27	2.31	1.16496896	29.87	29.49	1.30
0x17	1200	1.13744593	29.17	30.77	-5.21	1.24881434	56.76	54.55	4.07	1.21599284	31.18	30.77	1.33

Table 8. Raw Data for 94 μ F Input / 10 μ F Output Capacitor

47µF		Green			Red			Blue					
		Meas	Calc	% Error	Meas	Calc	% Error	Meas	Calc	% Error			
0x00	50	0.05284997	1.36	1.28	5.70	0.05572375	2.53	2.27	11.45	0.05597801	1.44	1.28	11.98
0x01	100	0.10446982	2.68	2.56	4.47	0.10880488	4.95	4.55	8.80	0.10849779	2.78	2.56	8.50
0x02	150	0.15602785	4.00	3.85	4.02	0.1627258	7.40	6.82	8.48	0.16003556	4.10	3.85	6.69
0x03	200	0.20705548	5.31	5.13	3.53	0.21487117	9.77	9.09	7.44	0.21083247	5.41	5.13	5.42
0x04	250	0.25767828	6.61	6.41	3.07	0.26757125	12.16	11.36	7.03	0.26153132	6.71	6.41	4.61
0x05	300	0.308024	7.90	7.69	2.67	0.31904542	14.50	13.64	6.35	0.312157	8.00	7.69	4.05
0x06	350	0.35835892	9.19	8.97	2.39	0.37227837	16.92	15.91	6.37	0.36272472	9.30	8.97	3.64
0x07	400	0.40828701	10.47	10.26	2.07	0.42390311	19.27	18.18	5.98	0.41316941	10.59	10.26	3.29
0x08	450	0.45843415	11.75	11.54	1.87	0.47591661	21.63	20.45	5.76	0.46369158	11.89	11.54	3.04
0x09	500	0.50819755	13.03	12.82	1.64	0.53043107	24.11	22.73	6.09	0.51395828	13.18	12.82	2.79
0x0A	550	0.55824129	14.31	14.10	1.50	0.58225828	26.47	25.00	5.87	0.56444652	14.47	14.10	2.63
0x0B	600	0.60809776	15.59	15.38	1.35	0.63292883	28.77	27.27	5.49	0.61435939	15.75	15.38	2.39
0x0C	650	0.65889063	16.89	16.67	1.37	0.68554104	31.16	29.55	5.47	0.6645481	17.04	16.67	2.24
0x0D	700	0.7096786	18.20	17.95	1.38	0.73836305	33.56	31.82	5.48	0.7146985	18.33	17.95	2.10
0x0E	750	0.75915353	19.47	19.23	1.22	0.79074113	35.94	34.09	5.43	0.76616247	19.65	19.23	2.15
0x0F	800	0.80958737	20.76	20.51	1.20	0.84278624	38.31	36.36	5.35	0.81768077	20.97	20.51	2.21
0x10	850	0.8598852	22.05	21.79	1.16	0.88893407	40.41	38.64	4.58	0.86730782	22.24	21.79	2.04
0x11	900	0.91044416	23.34	23.08	1.16	0.91066016	41.39	40.91	1.18	0.91824571	23.54	23.08	2.03
0x12	950	0.92981981	23.84	24.36	-2.12	0.93188495	42.36	43.18	-1.91	0.96880778	24.84	24.36	1.98
0x13	1000	0.94497926	24.23	25.64	-5.50	0.9607309	43.67	45.45	-3.93	1.01981203	26.15	25.64	1.98
0x14	1050	0.96604538	24.77	26.92	-8.00	1.0042516	45.65	47.73	-4.36	1.07105886	27.46	26.92	2.01
0x15	1100	1.00018289	25.65	28.21	-9.07	1.07300547	48.77	50.00	-2.45	1.12235726	28.78	28.21	2.03
0x16	1150	1.05221671	26.98	29.49	-8.50	1.17405224	53.37	52.27	2.09	1.17247753	30.06	29.49	1.95
0x17	1200	1.12718062	28.90	30.77	-6.07	1.26327698	57.42	54.55	5.27	1.22272863	31.35	30.77	1.89

Table 9. Raw Data for 47uF Input / 47uF Output Capacitor

47 μ F		Green			Red			Blue					
		Meas	Calc	% Error	Meas	Calc	% Error	Meas	Calc	% Error			
0x00	50	0.05291514	1.36	1.28	5.83	0.05539243	2.52	2.27	10.78	0.05601921	1.44	1.28	12.04
0x01	100	0.10462567	2.68	2.56	4.63	0.10912348	4.96	4.55	9.12	0.10843575	2.78	2.56	8.44
0x02	150	0.1564698	4.01	3.85	4.31	0.1625579	7.39	6.82	8.37	0.15990617	4.10	3.85	6.60
0x03	200	0.20741859	5.32	5.13	3.71	0.21504034	9.77	9.09	7.52	0.21036629	5.39	5.13	5.18
0x04	250	0.25806276	6.62	6.41	3.23	0.26746106	12.16	11.36	6.98	0.26173763	6.71	6.41	4.70
0x05	300	0.30814908	7.90	7.69	2.72	0.31994793	14.54	13.64	6.65	0.31229453	8.01	7.69	4.10
0x06	350	0.35868465	9.20	8.97	2.48	0.37261995	16.94	15.91	6.46	0.36260267	9.30	8.97	3.60
0x07	400	0.40914515	10.49	10.26	2.29	0.42412714	19.28	18.18	6.03	0.41311657	10.59	10.26	3.28
0x08	450	0.45877138	11.76	11.54	1.95	0.47657509	21.66	20.45	5.91	0.46399478	11.90	11.54	3.11
0x09	500	0.50855585	13.04	12.82	1.71	0.53012237	24.10	22.73	6.02	0.51392322	13.18	12.82	2.78
0x0A	550	0.55900969	14.33	14.10	1.64	0.5829086	26.50	25.00	5.98	0.56458547	14.48	14.10	2.65
0x0B	600	0.60911462	15.62	15.38	1.52	0.63359852	28.80	27.27	5.60	0.61437464	15.75	15.38	2.40
0x0C	650	0.65890809	16.90	16.67	1.37	0.68622949	31.19	29.55	5.57	0.66458817	17.04	16.67	2.24
0x0D	700	0.71044378	18.22	17.95	1.49	0.73885477	33.58	31.82	5.55	0.71513022	18.34	17.95	2.16
0x0E	750	0.76011529	19.49	19.23	1.35	0.79096045	35.95	34.09	5.46	0.76657382	19.66	19.23	2.21
0x0F	800	0.81060667	20.78	20.51	1.33	0.84223802	38.28	36.36	5.28	0.81806824	20.98	20.51	2.26
0x10	850	0.86115742	22.08	21.79	1.31	0.8937373	40.62	38.64	5.15	0.86766599	22.25	21.79	2.08
0x11	900	0.91173149	23.38	23.08	1.30	0.92951703	42.25	40.91	3.28	0.91850303	23.55	23.08	2.06
0x12	950	0.93476316	23.97	24.36	-1.60	0.95465707	43.39	43.18	0.49	0.96900081	24.85	24.36	2.00
0x13	1000	0.95066682	24.38	25.64	-4.93	0.98530644	44.79	45.45	-1.47	1.0201794	26.16	25.64	2.02
0x14	1050	0.97236449	24.93	26.92	-7.39	1.03180084	46.90	47.73	-1.73	1.07079682	27.46	26.92	1.98
0x15	1100	1.00661917	25.81	28.21	-8.49	1.10290594	50.13	50.00	0.26	1.12191533	28.77	28.21	1.99
0x16	1150	1.05867592	27.15	29.49	-7.94	1.20250549	54.66	52.27	4.57	1.17251081	30.06	29.49	1.96
0x17	1200	1.13346901	29.06	30.77	-5.54	1.26252175	57.39	54.55	5.21	1.22278686	31.35	30.77	1.90

Table 10. Raw Data for 94 μ F Input / 47 μ F Output Capacitor

94 μ F		Green			Red			Blue					
		Meas	Calc	% Error	Meas	Calc	% Error	Meas	Calc	% Error			
0x00	50	0.05198738	1.33	1.28	3.93	0.05478907	2.49	2.27	9.58	0.05419975	1.39	1.28	8.40
0x01	100	0.103065	2.64	2.56	3.07	0.10768332	4.89	4.55	7.68	0.1058245	2.71	2.56	5.82
0x02	150	0.15412767	3.95	3.85	2.75	0.16099784	7.32	6.82	7.33	0.1572915	4.03	3.85	4.88
0x03	200	0.20490047	5.25	5.13	2.45	0.21394376	9.72	9.09	6.97	0.20848153	5.35	5.13	4.24
0x04	250	0.25549392	6.55	6.41	2.20	0.26762751	12.16	11.36	7.05	0.25987867	6.66	6.41	3.95
0x05	300	0.30603438	7.85	7.69	2.01	0.31921234	14.51	13.64	6.40	0.31047097	7.98	7.69	3.49
0x06	350	0.3565531	9.14	8.97	1.87	0.37237293	16.93	15.91	6.39	0.36143307	9.27	8.97	3.27
0x07	400	0.40703449	10.44	10.26	1.76	0.42561801	19.35	18.18	6.40	0.41235934	10.57	10.26	3.09
0x08	450	0.45719809	11.72	11.54	1.60	0.47891979	21.77	20.45	6.43	0.46312996	11.88	11.54	2.92
0x09	500	0.50785377	13.02	12.82	1.57	0.53177389	24.17	22.73	6.35	0.51383347	13.18	12.82	2.77
0x0A	550	0.55790184	14.31	14.10	1.44	0.58490111	26.59	25.00	6.35	0.5641612	14.47	14.10	2.57
0x0B	600	0.60806349	15.59	15.38	1.34	0.63761642	28.98	27.27	6.27	0.61527414	15.78	15.38	2.55
0x0C	650	0.65926581	16.90	16.67	1.43	0.69060046	31.39	29.55	6.25	0.66692751	17.10	16.67	2.60
0x0D	700	0.70934843	18.19	17.95	1.34	0.74316386	33.78	31.82	6.17	0.71791896	18.41	17.95	2.58
0x0E	750	0.76007223	19.49	19.23	1.34	0.79570772	36.17	34.09	6.09	0.76877243	19.71	19.23	2.50
0x0F	800	0.81059966	20.78	20.51	1.32	0.84789002	38.54	36.36	5.99	0.81975818	21.02	20.51	2.47
0x10	850	0.86228285	22.11	21.79	1.45	0.88138006	40.06	38.64	3.69	0.87071806	22.33	21.79	2.44
0x11	900	0.91005099	23.33	23.08	1.12	0.90063212	40.94	40.91	0.07	0.92183687	23.64	23.08	2.43
0x12	950	0.93013376	23.85	24.36	-2.09	0.92022659	41.83	43.18	-3.13	0.97296767	24.95	24.36	2.42
0x13	1000	0.94551178	24.24	25.64	-5.45	0.94770514	43.08	45.45	-5.23	1.02425197	26.26	25.64	2.43
0x14	1050	0.9666595	24.79	26.92	-7.94	0.99105021	45.05	47.73	-5.61	1.07558802	27.58	26.92	2.44
0x15	1100	1.00054072	25.65	28.21	-9.04	1.05860334	48.12	50.00	-3.76	1.12305367	28.80	28.21	2.10
0x16	1150	1.05244688	26.99	29.49	-8.48	1.15948375	52.70	52.27	0.82	1.17836679	30.21	29.49	2.47
0x17	1200	1.12710175	28.90	30.77	-6.07	1.27185882	57.81	54.55	5.99	1.22905678	31.51	30.77	2.42

Table 11. Raw Data for 47 μ F Input / 94 μ F Output Capacitor

94µF		Green			Red			Blue					
		Meas	Calc	% Error	Meas	Calc	% Error	Meas	Calc	% Error			
0x00	50	0.05200697	1.33	1.28	4.01	0.05436706	2.47	2.27	8.73	0.05426098	1.39	1.28	8.52
0x01	100	0.10356678	2.66	2.56	3.57	0.10741029	4.88	4.55	7.41	0.10632832	2.73	2.56	6.33
0x02	150	0.1542082	3.95	3.85	2.81	0.16045634	7.29	6.82	6.97	0.15769801	4.04	3.85	5.13
0x03	200	0.20524837	5.26	5.13	2.62	0.21290037	9.68	9.09	6.45	0.20863386	5.35	5.13	4.32
0x04	250	0.25610078	6.57	6.41	2.44	0.26618547	12.10	11.36	6.47	0.25931849	6.65	6.41	3.73
0x05	300	0.30645528	7.86	7.69	2.15	0.31828622	14.47	13.64	6.10	0.3099029	7.95	7.69	3.30
0x06	350	0.3572653	9.16	8.97	2.08	0.36985684	16.81	15.91	5.67	0.36067985	9.25	8.97	3.05
0x07	400	0.40774651	10.46	10.26	1.94	0.42234751	19.20	18.18	5.59	0.41182698	10.56	10.26	2.96
0x08	450	0.45800112	11.74	11.54	1.78	0.47483759	21.58	20.45	5.52	0.46222067	11.85	11.54	2.72
0x09	500	0.50869042	13.04	12.82	1.74	0.52873399	24.03	22.73	5.75	0.51296907	13.15	12.82	2.59
0x0A	550	0.55827629	14.31	14.10	1.50	0.58164023	26.44	25.00	5.75	0.56320472	14.44	14.10	2.40
0x0B	600	0.60854326	15.60	15.38	1.42	0.63388916	28.81	27.27	5.65	0.61428574	15.75	15.38	2.38
0x0C	650	0.65988213	16.92	16.67	1.52	0.68597037	31.18	29.55	5.53	0.66513881	17.05	16.67	2.33
0x0D	700	0.71048867	18.22	17.95	1.50	0.73909677	33.60	31.82	5.59	0.7189713	18.38	17.95	2.42
0x0E	750	0.76074182	19.51	19.23	1.43	0.79136279	35.97	34.09	5.52	0.76812468	19.70	19.23	2.42
0x0F	800	0.8112982	20.80	20.51	1.41	0.84310076	38.32	36.36	5.39	0.81840901	20.98	20.51	2.30
0x10	850	0.86227747	22.11	21.79	1.44	0.89487317	40.68	38.64	5.28	0.86932097	22.29	21.79	2.27
0x11	900	0.91322873	23.42	23.08	1.47	0.92747895	42.16	40.91	3.05	0.91998515	23.59	23.08	2.22
0x12	950	0.94056779	24.12	24.36	-0.99	0.95254878	43.30	43.18	0.27	0.97092654	24.90	24.36	2.20
0x13	1000	0.95720889	24.54	25.64	-4.28	0.98313275	44.69	45.45	-1.69	1.02202162	26.21	25.64	2.20
0x14	1050	0.97886934	25.10	26.92	-6.77	1.02896735	46.77	47.73	-2.00	1.07298488	27.51	26.92	2.19
0x15	1100	1.01336698	25.98	28.21	-7.88	1.0986225	49.94	50.00	-0.13	1.12462839	28.84	28.21	2.24
0x16	1150	1.06548863	27.32	29.49	-7.35	1.19693633	54.41	52.27	4.08	1.17503361	30.13	29.49	2.18
0x17	1200	1.14029463	29.24	30.77	-4.98	1.26581559	57.54	54.55	5.48	1.22561547	31.43	30.77	2.13

Table 12. Raw Data for 94µF Input / 94µF Output Capacitor

About the Author

Name: Craig Cary

Background: Craig earned a B.S. in Electrical Engineering from California Polytechnic State University in San Luis Obispo. Presently, he is working with Configurable Mixed-Signal ICs (CMICs) as an application engineer for Silego Technology.

Contact: appnotes@silego.com

Files

- [AN-1209 Constant Current RGB LED Driver.gp5](#)- (38 KB)
- [AN-1209 Constant Current RGB LED Driver.pdf](#)- (799 KB)
- [AN-1209.zip](#)- (713 KB)

[See full list of Application Notes](#)