

IMPORTANT LAYOUT NOTES:

1. FB2 right next to OUT+ on Top side of PCB
2. FB1 right next to OUT- on Top side of PCB
3. C2, C10, C3 and C11 right next to PVDD pin on TOP side of PCB
4. L1 and L2 right next to J5

Additional Filter
(if filter is not used shorting points to be soldered)

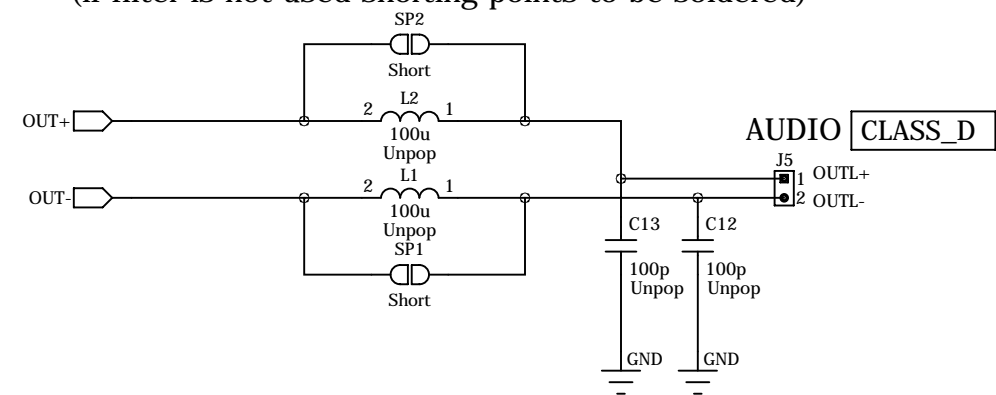

TITLE: DA7202		DRAWING NO: 189-01-A		REV: A
PREPARED:	DATED: 28/03/2013	SHEET NAME:		PAGE: 1 OF 1
RESPONSIBLE:	DATED: 28/03/2013			

